

CODICE / Item no.

RTE

Materiale: 16 Cr Ni 4
Material: 16 Cr Ni 4

Trattamento termico:
cementazione + tempra
Heat treatment: cementing

Durezza: Hrc 61÷ 63
Hardness: Hrc 61÷63

RONDELLA PER COLONNA CGE WASHERS FOR PILLARS CGE

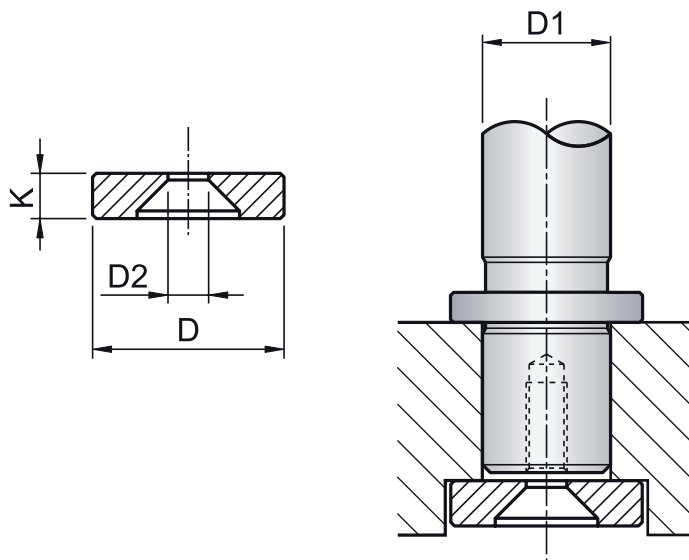

| CODICE | D1 | D | K | D2 |
|--------|-------|----|----|----|
| RTE 1 | 18-19 | 25 | 6 | 9 |
| RTE 2 | 24-25 | 32 | 7 | 11 |
| RTE 3 | 30-32 | 40 | 7 | 11 |
| RTE 4 | 40-42 | 50 | 9 | 13 |
| RTE 5 | 50-52 | 62 | 9 | 13 |
| RTE 6 | 63 | 73 | 9 | 13 |
| RTE 7 | 80 | 93 | 12 | 13 |

ESEMPIO DI ORDINAZIONE RTE D - ORDERING EXAMPLE RTE D

STAFFETTE DI RITEGNO

RETAINING CLAMPS

CODICE / Item no.

STAFF

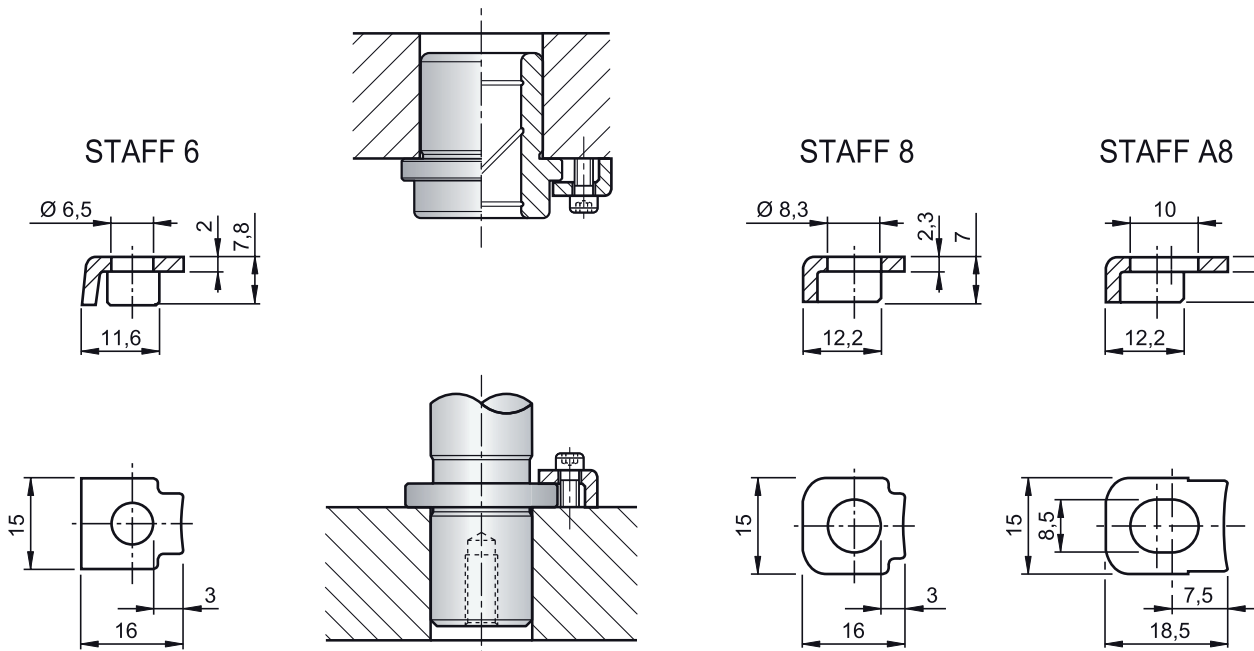

| | | | | |
|-----|--------------------|----|-----------------------------|--------------------------|
| N°3 | STAFFETTE / CLAMPS | M6 | dal / from $\varnothing 18$ | al / to $\varnothing 25$ |
| N°3 | STAFFETTE / CLAMPS | M8 | dal / from $\varnothing 30$ | al / to $\varnothing 80$ |

ESEMPIO DI ORDINAZIONE STAFF (6-8-A8)
ORDERING EXAMPLE STAFF (6-8-A8)

VITI PER STAFFETTE

SCREWS FOR CLAMPS

CODICE / Item no.

VITI

