

*Cilindri all'azoto per stampi*

**Nitrogen gas springs** for press tools, dies and moulds

High performance line



True quality lives in time  
*La vera qualità si esprime nel tempo*





Indice

# Index

Bordignon company – <i>L'azienda Bordignon</i>	04
Certified quality – <i>Qualità certificata</i>	05
Safety & FMEA – <i>Sicurezza e FMEA</i>	06
Power & compactness, reliability – <i>Potenza e compattezza, affidabilità</i>	07
Nano technology WIPERTECH – <i>Nano tecnologia WIPERTECH</i>	08
Nano technology NANOTECH2 – <i>Nano tecnologia NANOTECH2</i>	09
Use instructions – <i>Istruzioni per l'uso</i>	10
Information & Catalogue help – <i>Informazioni e Uso del catalogo</i>	11
Product series tables (available diameters, forces and stroke lengths, maximum allowed working cycles/minute) – <i>Tabelle serie prodotti (diametri, forze e corse disponibili, cicli massimi di lavoro/minuto consentiti)</i>	12-17
Production program – <i>Programma di produzione</i>	19
Product technical specifications – <i>Specifiche tecniche dei prodotti</i>	20-55



Active since 1958, Bordignon was the first company producing springs for molds and nitrogen gas springs to have obtained the UNI EN ISO 9002 (now UNI EN ISO 9001) certificate for the implementation of the Quality System to its production process, totally inside the company and controlled at every stage, from the acceptance of raw materials to the storage of the finished product.

Besides commitment to quality, the company adds the constant search for innovative solutions to provide specific answers to the most diverse use conditions.

### **Service and technological creativity: Bordignon makes the difference**

Taking care of the customer needs is the starting point for Bordignon research, which is aimed at offering customized nitrogen gas springs in a market characterized by standard solutions.

That's how dedicated products, perfect blends of nano-technologies and new materials synthesis, are designed to ensure safety and reliability over time, generating quality in the production processes in which they are involved.

Safety, research and development, production with no outsourcing, quality, big stock for quick delivery, have always been the points of strength of the Bordignon company.

*Attiva dal 1958, Bordignon è stata la prima realtà produttrice di molle per stampi e cilindri all'azoto ad aver ottenuto la Certificazione UNI EN ISO 9002 (ora UNI EN ISO 9001) per l'applicazione del Sistema Qualità al suo processo produttivo, totalmente interno e controllato in ogni fase, dall'accettazione delle materie prime sino allo stoccaggio del prodotto finito.*

*All'impegno sulla qualità l'azienda aggiunge la costante ricerca di soluzioni innovative per fornire risposte specifiche alle più diverse condizioni di utilizzo.*

### **Servizio e creatività tecnologica: così Bordignon fa la differenza**

*Dal confronto con le esigenze dei propri clienti, Bordignon trae i motivi della sua ricerca, tesa a proporre cilindri personalizzati in un mercato caratterizzato da soluzioni standard. Nascono così prodotti ad hoc, perfetti insiemi di nano-tecnologie e nuovi materiali di sintesi, pensati per assicurare sicurezza nelle prestazioni e affidabilità nel tempo, generatori di qualità nei processi produttivi in cui vengono coinvolti.*

*Sicurezza, ricerca e sviluppo, produzione senza outsourcing, qualità, grande disponibilità a magazzino per consegne veloci, contraddistinguono da sempre l'azienda Bordignon.*





Qualità certificata

# Certified quality



The Bordignon nitrogen gas springs are designed and built to guarantee the longest service life: they are the end result of many years of experience, research and innovative technology rewarded by the UNI EN ISO 9001 CERTIFICATION. More than 1000 nitrogen gas springs have been standardized and listed in this catalogue: they're in stock for immediate delivery, charged and ready for use. Bordignon also produces tailor made nitrogen gas springs on request.

**THE BORDIGNON NITROGEN GAS SPRINGS, IF PROPERLY USED, WILL LAST MORE THAN 200.000.000 mm OF TOTAL STROKE IN NORMAL WORKING CONDITIONS.**

*I cilindri Bordignon sono affidabili e durano a lungo poiché sono il risultato di anni d'esperienza, ricerca e innovazione, premiate dalla CERTIFICAZIONE UNI EN ISO 9001.*

*Il catalogo presenta oltre 1000 cilindri autonomi già caricati e pronti all'uso, normalmente a magazzino per una rapida consegna.*

*A richiesta vengono forniti cilindri e sistemi di cilindri non standard.*

**SE CORRETTAMENTE USATI, I CILINDRI BORDIGNON HANNO UNA DURATA DI OLTRE 200.000.000 mm DI CORSA TOTALE IN NORMALI CONDIZIONI DI UTILIZZO.**



**CERTIFICATO N° 009SGQ07**  
*CERTIFICATE N° 009SGQ07*

Si certifica che il  
*this is to certify that*  
Sistema di Gestione per la Qualità  
*Quality Management System*  
messo in atto da  
*implemented by*  
**BORDIGNON S.r.l.**  
Via Alessandro Volta, 2 – IT 36028 ROSSANO VENETO (VI)  
nella Sede Operativa di  
*Operative Unit*  
Zona Industriale, 5 - IT 38055 GRIGNO (TN)  
è conforme alla norma  
*is in compliance with the standard*  
**UNI EN ISO 9001-2015 (ISO 9001-2015)**  
per i seguenti Processi  
*concerning the following kinds of Processes*  
**Progettazione e fabbricazione di cilindri e serbatoi all'azoto, espulsori, cilindri all'azoto per manifold e manifold**  
*Design and production of nitrogen gas springs and tanks, ejectors, nitrogen gas springs for manifold and manifold*

Il presente Certificato è soggetto al rispetto delle condizioni stabilite dai Regolamenti per la certificazione in vigore applicabili. *This Certificate is subject to the requirements established in the Regulation for certification in force applicable.*  
In caso di discrepanza tra le lingue utilizzate nella traduzione del contenuto del presente certificato, fare riferimento alla lingua italiana. *In case of discrepancy between the languages used in the translation of the content of this certificate, please refer to the Italian language.*

L'AMMINISTRATORE DELEGATO  
*MANAGING DIRECTOR*  
  
Dr. Ing. Roberto Cusolito

Data di Prima Emissione  
*First issue Date*  
2019-02-07

Data di Scadenza  
*Expiry Date*  
2020-10-15

Settore IAF 17

ITALCERT S.r.l. | Viale Sarca, 336 - 20126 Milano (MI) | tel. +39 0266104876 | fax. +39 026610479 | www.italcert.it | italcert@regmail.it

**TÜV**  
AUTOMOTIVE

**TÜV AUTOMOTIVE GMBH**  
Betriebsfestigkeit  
Ridlerstraße 57  
D - 80339 München

Seite 1

Auftrags-Nr.: 950 18675  
Prüf-Nr.: 950 18675/2  
Sachverständiger : Herr Glas  
TA - MU - BF/mf

München, den 20.10.99  
Telefon: 089/ 5190-3357  
Fax : 089/ 5190-3368

**PRÜFBERICHT**

**TEST ORDERED BY:** BORDIGNON SPA  
Rossano Veneto - ITALY  
on July 9<sup>th</sup> 1999

**OBJECT OF THE TEST:** LIFETIME OF ON OILLESS GAS SPRING  
„C 038-50“  
UP TO 300.000 MT. OF TOTAL STROKE

**PLACE OF THE TEST:** TÜV AUTOMOTIVE GmbH  
Ridlerstraße 57  
D-80339 MUNICH

**TEST CONDITIONS:** STROKE: 50MM.  
FREQUENCY: 0,63 Hz  
WITHOUT LUBRIFICATION

**TEST RESULT:** THE CYLINDER WORKED WELL.  
AFTER 3.000.000 STROKES  
(= 300.000 MT.) IT WAS STILL CHARGED  
AND PERFORMING PERFECTLY.

**Betriebsfestigkeit**  
  
Dr.-Ing. A. Weiß

**Der Sachverständige**  
  
A. Glas

Die auszugsweise Wiedergabe dieses Prüfberichtes und die Verwendung zu Werbezwecken bedürfen der schriftlichen Genehmigung der TÜV Automotive GmbH

TÜV Automotive GmbH • Unternehmensgruppe TÜV SÜD AG München • Geschäftsführer: Dr.-Ing. Michael Seiblmayr  
Sitz: München • Amtsgericht München HRB 151 999 • Registervermerk München 274 843 - RZ 200 000 79  
Akcreditiert unter DAR-Registriernummer KBA-P 00001-95 von der Akkreditierungsstelle des Kraftfahrt-Bundesamtes, Bundesrepublik Deutschland.

# Safety & FMEA

Our points of strength

## SAFETY

Bordignon nitrogen gas springs have always been built with single ("monolithic") thick mechanical components, in order to ensure product integrity and maximum user's safety even under the most extreme wrong use conditions (collisions, etc.). The piston rod is blocked by a thick mechanical stop inside the cylinder body.

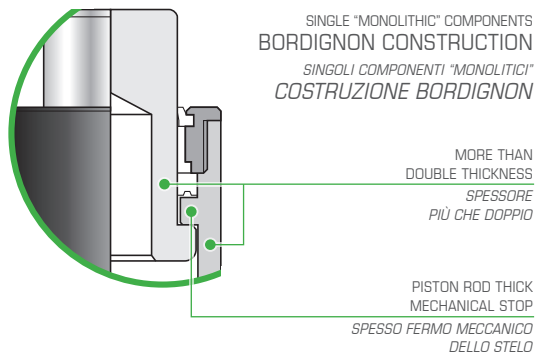

Bordignon gas spring components are coupled through thread connections, for the highest possible safety. Thread connections are standard in high pressure equipment around the world, such as waterjet cutting nozzles and ultra high pressure vessels (~10000 bar).

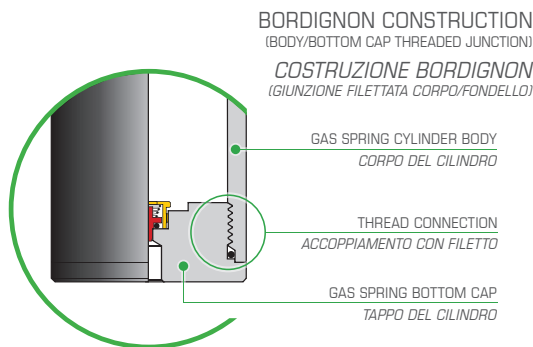

## FMEA - FAILURE MODE AND EFFECT ANALYSIS

Bordignon nitrogen gas springs have always been built with a safety system for both internal over-pressure and over-stroke: the cylinder body metal wall is thinner at the bottom and gets deformed in such critical conditions, allowing a safe gas spring discharge.



## SICUREZZA

Da sempre i cilindri all'azoto Bordignon sono costruiti con componenti meccanici singoli ("monolitici") di elevato spessore, per garantire l'integrità del prodotto e la massima sicurezza per l'utilizzatore anche nelle più estreme condizioni di errato utilizzo (collisioni, ecc.). Lo stelo è bloccato da un fermo meccanico di elevato spessore all'interno del corpo del cilindro.

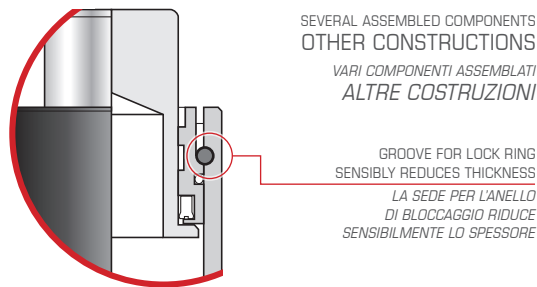

I componenti dei cilindri Bordignon sono assemblati tramite filetti, per assicurare la massima sicurezza possibile. Accoppiamenti tramite filetti sono uno standard su apparecchiature ad alta pressione in tutto il mondo, come ad esempio ugelli per il taglio ad acqua e recipienti a pressione ultra-elevata (~10000 bar).

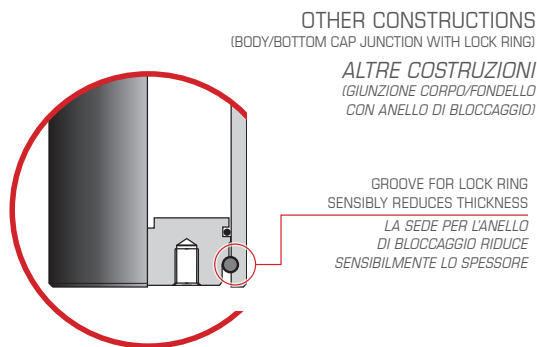

## FMEA - ANALISI DEI MODI E DEGLI EFFETTI DEI GUASTI

Da sempre i cilindri all'azoto Bordignon sono realizzati con un sistema di sicurezza in caso di extra-corsa o di pressione interna eccessiva: la parete metallica del corpo del cilindro è più sottile alla base e si deforma in tali condizioni critiche, consentendo lo scaricamento del cilindro in sicurezza.

# Power & compactness, reliability



Our points of strength

## POWER & COMPACTNESS

Bordignon produces various series of nitrogen gas springs, for every dimensional demand. Other than our ISO 11901 nitrogen gas spring line (Bordignon CISO series), we offer many other higher-performance models, with forces up to +300% higher and with much more compact dimensions.

## POTENZA E COMPATTEZZA

Bordignon produce diverse serie di cilindri all'azoto, per qualsiasi esigenza dimensionale. Oltre alla nostra serie di cilindri all'azoto a norma ISO 11901 (serie Bordignon CISO), offriamo molti altri modelli dalle prestazioni più elevate, con forze fino al +300% maggiori e con dimensioni molto più compatte.

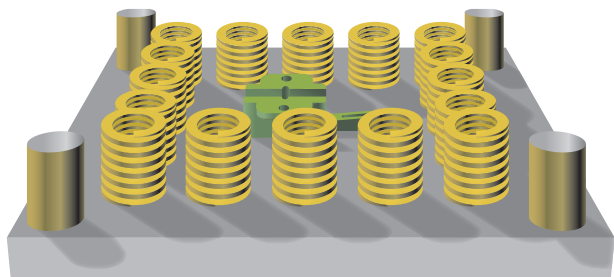

WIRE SPRINGS (LOW POWER)  
MOLLE A FILO (FORZA CONTENUTA)

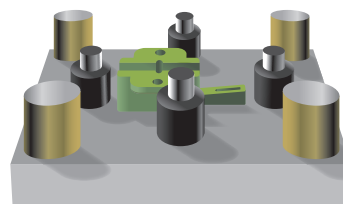

GAS SPRINGS (HIGH POWER)  
CILINDRI ALL'AZOTO (FORZA ELEVATA)

Reduction of die size translates into cost reduction and higher productivity, with advantages for both the die-maker and the die-user.

La riduzione delle dimensioni dello stampo si traduce in riduzione dei costi e migliore produttività, con vantaggi sia per lo stampista che per lo stampatore.

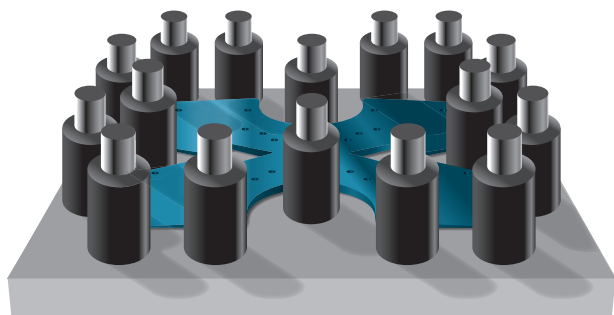

ISO 11901 GAS SPRINGS (BIG SIZE, LOW POWER)  
CILINDRI ISO 11901 (INGOMBRO ELEVATO, FORZA CONTENUTA)

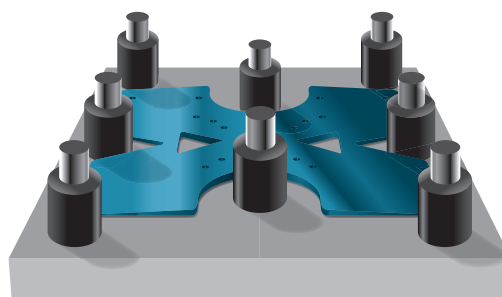

BORDIGNON HIGHER-POWER GAS SPRINGS (COMPACT SIZE, HIGH POWER)  
CILINDRI BORDIGNON CON FORZA INCREMENTATA (DIMENSIONI COMPATTE, FORZA ELEVATA)

## RELIABILITY

All Bordignon nitrogen gas springs (except for the TOP series) are self-lubricated, for millions of cycles, thanks to a solid lubricant (PATENT PENDING).

## AFFIDABILITÀ

Tutti i cilindri all'azoto Bordignon (tranne la serie TOP) sono autolubrificati, per milioni di cicli, grazie a un lubrificante solido (PATENT PENDING).

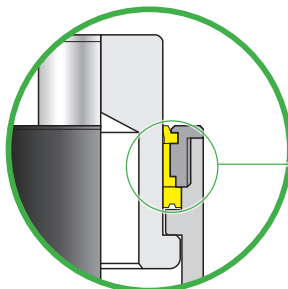

SELF-LUBRICATING  
SEALING SYSTEM  
GUARNIZIONI  
AUTOLUBRIFICANTI

# Nano technology

WIPESTECH and NANOTECH2



New technologies!

The nitrogen gas spring series CSX, SMLX, MSML, CX, CSMX, MICX and MCSM are now equipped with the **new WIPESTECH nano-technology**, which ensures (in comparison with the previous Bordignon models) an **improved protection against the liquid contaminants\*** that are often present in press dies, thus increasing the potential service life of nitrogen gas springs in such conditions (aggressive environment). The advantage for the end user is a considerable reduction of production stops thanks to the improved service life of the nitrogen gas springs even in an aggressive environment.

The following graph shows a relative comparison between the service life of the Bordignon nitrogen gas springs equipped with the **new WIPESTECH nano-technology** and the service life of the other two most durable nitrogen gas springs on the market (according to the tests performed by Bordignon\*). The data have been collected from tests that were performed by simulating an aggressive environment for the nitrogen gas springs. In all these comparison tests, the Bordignon gas spring and the corresponding "non-Bordignon" model have always been tested in the same identical use conditions: the result is that, **under the same use conditions with liquid contaminants, the service life of Bordignon nitrogen gas springs is from 2.5 up to 5 times longer** than the service life of the other gas springs\*.

I cilindri all'azoto delle serie CSX, SMLX, MSML, CX, CSMX, MICX e MCSM sono ora dotati della **nuova nano-tecnologia WIPESTECH**, che assicura (rispetto ai precedenti modelli Bordignon) una migliore **protezione dai contaminanti liquidi\*** spesso presenti sugli stampi, incrementando così la potenziale durata dei cilindri all'azoto in tali condizioni d'uso (ambiente aggressivo). Il vantaggio per l'utilizzatore è la notevole riduzione dei fermi di produzione grazie alla migliore durata dei cilindri all'azoto anche in ambiente aggressivo.

Il grafico seguente illustra la durata relativa dei cilindri all'azoto Bordignon dotati della **nuova nano-tecnologia WIPESTECH** rispetto alla durata degli altri due più durevoli cilindri all'azoto presenti sul mercato, individuati sulla base dei test svolti da Bordignon\*.

I dati sono stati raccolti da test effettuati simulando un ambiente aggressivo per i cilindri all'azoto. In tutti i test comparativi, il cilindro Bordignon e il rispettivo "non Bordignon" sono sempre stati testati in condizioni di utilizzo identiche: il risultato è che **nelle stesse condizioni d'uso con contaminanti liquidi, la durata dei cilindri all'azoto Bordignon è dalle 2,5 alle 5 volte più lunga** di quella degli altri cilindri\*.

DURABILITY UNDER THE SAME OPERATING CONDITIONS - WITH LIQUID CONTAMINANTS\*  
DURATA NELLE STESSA CONDIZIONI DI UTILIZZO - CON CONTAMINANTI LIQUIDI\*

(The graph shows reference values / Il grafico mostra valori di riferimento)

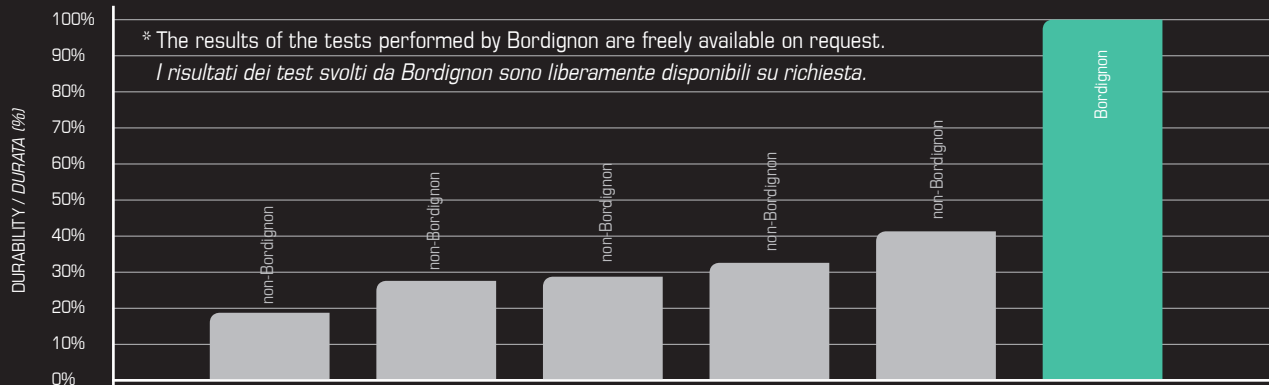



The performance and durability of Bordignon nitrogen gas springs have been upgraded to a higher level thanks to the introduction of the **new NANOTECH2 nanotechnologies**, now improved over the previous version and also extended to the gas spring series CSX, SMLX, MSML, CX, CSMX, MICX and MCSM. The **new NANOTECH2 nano-technologies** allow to increase the working speed / cycles per minute by 150% (more than double) in comparison with the previous Bordignon standard models, with no external lubrication. The advantage for the end user is a 60% time reduction for batch production / press use. The **new NANOTECH2 nano-technologies** also allow to increase – in a considerable way (even more than with the previous version) – the service life of nitrogen gas springs in case of a non-perpendicular-to-the-base piston rod working stroke. The advantage for both the die user and the die maker is a considerable reduction of production stops because of anomalies in the construction/setup and use of press dies.

The nitrogen gas springs with the **new NANOTECH2 nano-technologies** passed the durability test of 2 million working cycles with a piston rod eccentricity of 1° (1.76 mm / 100 mm)\*. Eccentricity up to 1.3° (2.27 mm / 100 mm) was also tested. The tests were performed with working stroke lengths up to 80 mm\*. The proper use of nitrogen gas springs, which allows to get a longer service life, is with a perpendicular-to-the-base piston rod working stroke and with the gas spring mounted according to the allowed fixing possibilities.

The following graph shows a relative comparison between the service life of the Bordignon nitrogen gas springs equipped with the **new NANOTECH2 nano-technologies** and the service life of the other six most durable nitrogen gas springs on the market (according to the tests performed by Bordignon\*). The data have been collected from tests that were performed in several, different use conditions. In all these comparison tests, the Bordignon gas spring and the corresponding “non-Bordignon” model have always been tested in the same identical use conditions: the result is that, **under the same use conditions, the service life of Bordignon nitrogen gas springs is from 2.5 up to 10 times longer** than the service life of the other gas springs\*.

Performance e durata dei cilindri all'azoto Bordignon raggiungono un livello ancora più alto con l'introduzione delle **nuove nano-tecnologie NANOTECH2**, migliorate rispetto alla versione precedente ed estese ai cilindri delle serie CSX, SMLX, MSML, CX, CSMX, MICX e MCSM. Le **nuove nano-tecnologie NANOTECH2** permettono di aumentare la velocità di lavoro / cicli al minuto del 150% (più del doppio) rispetto ai precedenti modelli standard Bordignon, senza apporto di lubrificazione esterna. Il vantaggio per l'utilizzatore è l'impiego di un tempo fino al 60% più basso (meno che dimezzato) per ogni lotto di produzione / impegno pressa. Le **nuove nano-tecnologie NANOTECH2** permettono inoltre di incrementare, in modo ancora più sensibile rispetto alla versione precedente, la durata dei cilindri all'azoto in caso di corsa di lavoro dello stelo non perpendicolare alla base. Il vantaggio per l'utilizzatore e lo stampista è la notevole riduzione dei fermi di produzione dovuti ad anomalie costruttive o di utilizzo dello stampo.

Con le **nuove nano-tecnologie NANOTECH2** i cilindri hanno superato il test di 2 milioni di colpi con inclinazione dello stelo pari a 1° (1,76 mm / 100 mm)\*. Sono stati effettuati anche test con inclinazione fino a 1,3° (2,27 mm / 100 mm). Sono stati testati cilindri con corse fino a 80 mm\*. L'utilizzo corretto, che consente una maggiore durata dei cilindri all'azoto, è con corsa di lavoro dello stelo perpendicolare alla base e con il cilindro montato secondo i fissaggi consentiti.

Il grafico seguente illustra la durata relativa dei cilindri all'azoto Bordignon dotati delle **nuove nano-tecnologie NANOTECH2** rispetto alla durata degli altri sei più durevoli cilindri all'azoto presenti sul mercato, individuati sulla base dei test svolti da Bordignon\*. I dati sono stati raccolti da test effettuati in molteplici condizioni d'uso. In tutti i test comparativi, il cilindro Bordignon e il rispettivo “non Bordignon” sono sempre stati testati in condizioni di utilizzo identiche: il risultato è che **nelle stesse condizioni d'uso la durata dei cilindri all'azoto Bordignon è dalle 2,5 alle 10 volte più lunga** di quella degli altri cilindri\*.

DURABILITY UNDER THE SAME OPERATING CONDITIONS\*  
DURATA NELLE STESSER CONDIZIONI DI UTILIZZO\*

(The graph shows reference values / Il grafico mostra valori di riferimento)

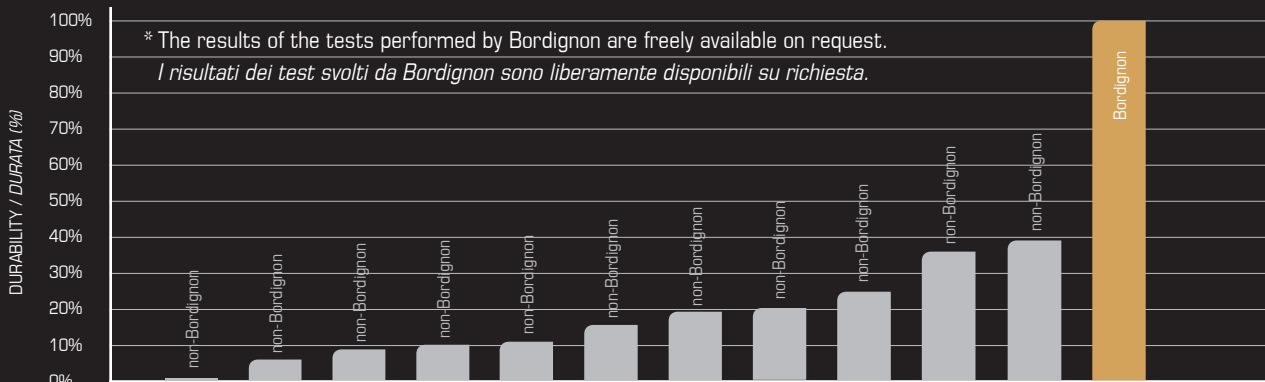

The following graphs instead show, in absolute terms, the service life of the Bordignon nitrogen gas springs equipped with the **new NANOTECH2 nano-technologies** in some specific tests performed at high speed or with a piston rod eccentricity of 1° (1.76 mm / 100 mm).

I grafici seguenti illustrano invece la durata assoluta dei cilindri all'azoto Bordignon dotati delle **nuove nano-tecnologie NANOTECH2** in alcuni specifici test effettuati ad alta velocità oppure con inclinazione dello stelo pari a 1° (1,76 mm / 100 mm).

## HIGH SPEED TEST / TEST AD ALTA VELOCITÀ

Durability test result / Risultato dei test di durata

MODEL MODELLO	STROKE CORSA	WORKING SPEED VELOCITÀ DI LAVORO	INCLINATION INCLINAZIONE
<b>CSX 19-25</b>	25 mm	250 cycles/minute cicli/minuto	0°
<b>SMLX 25-25</b>	25 mm	250 cycles/minute cicli/minuto	0°

(The graph shows reference values / Il grafico mostra valori di riferimento)

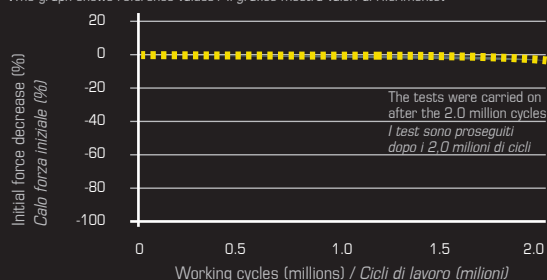

## ECCENTRICITY TEST / TEST CON INCLINAZIONE

Durability test result / Risultato dei test di durata

MODEL MODELLO	STROKE CORSA	WORKING SPEED VELOCITÀ DI LAVORO	INCLINATION INCLINAZIONE
<b>CSX 32-50</b>	48 mm	50 cycles/minute cicli/minuto	1° (1.76 mm / 100 mm)
<b>SMLX 38-38</b>	35 mm	70 cycles/minute cicli/minuto	1° (1.76 mm / 100 mm)

(The graph shows reference values / Il grafico mostra valori di riferimento)

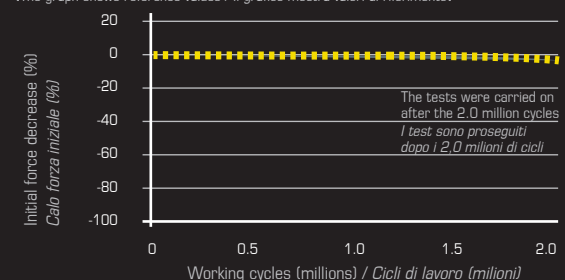

# Use instructions

## no



The threaded hole on the piston rod is for maintenance purposes only. Do not use it for fastening the nitrogen gas spring.

*Il foro filettato sullo stelo è da utilizzarsi unicamente per la manutenzione. Non utilizzarlo per fissare il cilindro.*



No side forces. Work stroke always perpendicular to the base of the nitrogen gas spring.

*No forze laterali. Corsa di lavoro perpendicolare alla base del cilindro.*



Avoid scratching and scoring on the piston rod.

*Non scalfire o rigare lo stelo.*



Do not make mechanical work on the nitrogen gas spring.

*Non eseguire lavorazioni meccaniche sul cilindro.*



Do not disassemble the nitrogen gas spring. Maintenance only by authorized people. The authorization is given only after a class held by Bordignon.

*Non smontare il cilindro. Manutenzione solo da personale autorizzato. L'autorizzazione è concessa solo dopo un corso fatto da Bordignon.*



Max impact and max release speed: 1 m/s (TOP series: 0.5 m/s). Maximum number of working cycles per minute: see product series tables in the catalogue (pages 12-17).

*Massima velocità d'impatto e di rilascio: 1 m/s (serie TOP: 0,5 m/s). Numero massimo di cicli di lavoro/minuto: vedi tabelle serie prodotti sul catalogo (pagine 12-17).*



Do not freely release the piston rod.

The piston rod goes up together with the press.

If the screws used for the base-mounting are broken or deformed (stretched), find out the possible causes and eliminate them: there might have been free/uncontrolled releases of the piston rod.

*Non rilasciare liberamente lo stelo.*

*Accompagnarlo con la pressa.*



*Se le viti utilizzate per il fissaggio alla base sono rotte o deformate (stirate), verificare ed eliminare le possibili cause: potrebbero esserci stati rilasci liberi/non controllati dello stelo.*



Protect against liquid or solid contaminants.

The nitrogen gas springs are protected against contaminants by scraper ring (except for the TOP series, EG series, CISO19 and CISO25 models).

Do not use chemical products with low flash point (petrol, solvents, alcohol, etc.).

Clean only with a dry cloth.

*Proteggere da emulsioni di stampaggio, detergenti, acqua e polveri.*

*I cilindri sono protetti da contaminanti con raschiastelo di protezione (tranne le serie TOP e EG e i modelli CISO19 e CISO25).*

*Non usare prodotti chimici con basso flash point (benzine, solventi, alcool, ecc.).*

*Pulire solo con un panno asciutto.*

The products in this catalogue are designed for the use in press tools, dies and moulds. We can not take any responsibility for any not proper or different use.

*I prodotti in questo catalogo sono progettati per l'utilizzo sugli stampi.*

*Non possiamo assumerci alcuna responsabilità in caso d'uso non corretto o diverso.*

## yes



Always fasten the nitrogen gas spring at the base to a flat and clean support surface with high resistance screws.

Gas springs with more than one threaded hole at the base: the center hole is for charging/discharging only. Use all the other holes at the base for fixing.



Flanged gas springs (CF and CSMF series): fasten the flange to a flat and clean support surface with high resistance screws. A safety plate must be present under the gas spring.

*Fissare sempre il cilindro alla base con viti ad alta resistenza su superficie piana e pulita.*

*Cilindri con più di un foro filettato alla base: il foro centrale è adibito al solo caricamento/scaricamento. Usare tutti gli altri fori alla base per il fissaggio.*

*Cilindri flangiati (serie CF e CSMF): fissare la flangia con viti ad alta resistenza su superficie piana e pulita. Una piastra di contenimento deve essere presente sotto il cilindro.*



Charge only with NITROGEN (N<sub>2</sub>).

*Caricare solo con AZOTO (N<sub>2</sub>).*



Hole for cylinder body  $\varnothing +1$  mm. Draining hole for liquids.

*Foro per cilindro  $\varnothing +1$  mm. Foro di scarico per liquidi.*



Lubricate the piston rod with grease with disulfide molybdenum (MoS<sub>2</sub>).

*Lubrificare lo stelo con grasso con bisolfuro di molibdeno (MoS<sub>2</sub>).*



Operating temperature: MIN 0°C (32°F) - MAX 80°C (176°F)

Do not heat.

*Temperatura di lavoro: MIN 0°C (32°F) - MAX 80°C (176°F)*

*Non riscaldare.*



Protect against solid contaminants with a metal bellow, liquid contaminants with a polymeric bellow.

Fasten the protection bellow to the die plate.



*Proteggere da contaminanti solidi con soffiETTO metallico e da contaminanti liquidi con soffiETTO polimerico, da fissare alla piastra dello stampo.*



IMPORTANT: periodically check for use instructions updates on our website. Pass the nitrogen gas springs use instructions to the end-user of the product.

*IMPORTANTE: controllare periodicamente gli aggiornamenti alle istruzioni per l'uso sul nostro sito web. Trasmettere le istruzioni per l'uso dei cilindri all'azoto all'utilizzatore del prodotto.*

- » Stroke available at 100%
- » You might adjust the initial force with the charging and discharging set (model COMPL)
- » Charging pressure: MIN 30 bar - MAX see table on catalogue
- » How to calculate the charging pressure (bar) for initial forces (daN) lower than  $F_{\text{initial in table}}$ :

$$\text{Charging pressure (bar)} = \frac{F \text{ (daN)} \times \text{max charging pressure (bar)}}{F_{\text{initial in table}}}$$

- » How to calculate the force (daN) at intermediate strokes:

$$F = F_{\text{initial}} + \frac{\text{intermediate stroke}}{\text{max stroke}} \times (F_{\text{final}} - F_{\text{initial}})$$

- » Please note: the final forces (forces at full stroke) indicated in the catalogue are reference values measured in static conditions. The actual final forces generated under use conditions may vary, since they depend on the specific parameters of the application, such as the working speed (cycles per minute).

- » *Corsa utilizzabile al 100%*
- » *Forza iniziale regolabile con il set di carico e scarico (modello COMPL)*
- » *Pressione di carico: MIN 30 bar - MAX vedere tabella sul catalogo*
- » *Calcolo della pressione di carico (bar) per forze iniziali (daN) minori della  $F_{\text{iniziale in tabella}}$ :*

$$\text{Pressione di carico (bar)} = \frac{F \text{ (daN)} \times \text{pressione massima di carico (bar)}}{F_{\text{iniziale in tabella}}}$$

- » *Calcolo della forza (daN) a corse intermedie:*

$$F = F_{\text{iniziale}} + \frac{\text{corsa intermedia}}{\text{corsa massima}} \times (F_{\text{finale}} - F_{\text{iniziale}})$$

- » *Nota: le forze finali (forze a fine corsa) indicate sul catalogo sono valori di riferimento misurati in condizioni statiche. Le forze finali reali sviluppate in fase di utilizzo possono variare, in quanto dipendono dagli specifici parametri dell'applicazione, come ad esempio la velocità di lavoro (cicli al minuto).*

## Uso del catalogo

# Catalogue help

### HOW TO ORDER

You order (example): **No. 8 CSX38-25**

You receive: 8 pieces CSX series nitrogen gas springs, ready for use, diameter Ø 38 mm, stroke 25 mm, initial force 1000daN (other specifications on CSX series page).

**ATTENTION:** whenever ordering CX, CSMX, CF, CSMF, CT and CSMT series gas springs, always specify the required initial force!

Examples: **No. 8 CSMX50-25 1500daN**

if you want CSMX50-25 gas springs charged at the standard initial force indicated in the catalogue.

**No. 8 CSMX50-25 1000daN**

if you want CSMX50-25 gas springs charged at a different initial force.

**SPECIAL SOLUTIONS:** different forces and strokes (not on catalogue) are available on request.

### GAS SPRING ACCESSORIES

Accessories for fixing, charging/discharging, linking to open system, etc. can be found in our "Accessories for nitrogen gas springs for dies" catalogue.

**ATTENTION:** use Bordignon nitrogen gas springs with Bordignon accessories only.

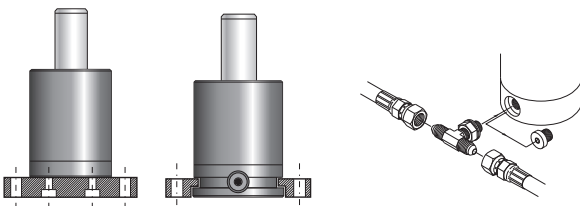

### 2D & 3D TECHNICAL DRAWINGS

Download various 2D & 3D file formats from [www.bordignon.com](http://www.bordignon.com)

### COME ORDINARE

Ordinate (esempio): **N° 8 CSX38-25**

Ricevete: 8 cilindri ad azoto serie CSX, pronti per l'uso, diametro Ø 38 mm, corsa 25 mm, forza iniziale 1000daN (altre specifiche sulla pagina della serie CSX).

**ATTENZIONE:** quando ordinate i cilindri ad azoto delle serie CX, CSMX, CF, CSMF, CT e CSMT, specificate sempre la forza richiesta!

Esempi: **N° 8 CSMX50-25 1500daN**

se volete cilindri CSMX50-25 caricati alla forza iniziale standard indicata sul catalogo.

**N° 8 CSMX50-25 1000daN**

se volete cilindri CSMX50-25 caricati ad una diversa forza iniziale.

**SOLUZIONI SPECIALI:** forze e corse diverse da quelle a catalogo sono disponibili a richiesta.

### ACCESSORI PER CILINDRI

Accessori per fissaggio, carico/scarico, collegamento a sistema, ecc. sul nostro catalogo "Accessori per cilindri all'azoto per stampi".

**ATTENZIONE:** usare i cilindri all'azoto Bordignon solamente con accessori Bordignon.



### DISEGNI TECNICI 2D E 3D

Vari formati 2D e 3D scaricabili dal sito [www.bordignon.com](http://www.bordignon.com)

Product range

# Nano technology series

Nitrogen gas springs for press tools, dies and moulds

Cilindri all'azoto per stampi

## CSX

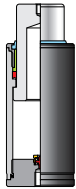

Ø mm	daN	STROKE / CORSA mm																	
		5	10	13	15	20	25	32	38	45	50	56	63	75	80	100	125	160	200
19	150		•		•	•	•	•	•	•	•	•	•	•		•			
25	300		•		•	•	•	•	•	•	•	•	•	•		•			
32	500		•		•	•	•	•	•	•	•	•	•	•		•			
32	660		•		•	•	•	•	•	•	•	•	•	•		•			
38	1000		•		•	•	•	•	•	•	•	•	•	•		•			
50	2000		•		•	•	•	•	•	•	•	•	•	•		•			
63	3000		•		•	•	•	•	•	•	•	•	•	•		•			
75	5000		•		•	•	•	•	•	•	•	•	•	•		•			
95	8000		•		•	•	•	•	•	•	•	•	•	•		•			

Maximum number of cycles per minute without lubrication  
Numero massimo di cicli/minuto senza lubrificazione

## SMLX

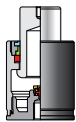

Ø mm	daN	STROKE / CORSA mm																	
		5	10	13	15	20	25	32	38	45	50	56	63	75	80	100	125	160	200
25	300	•	•	•	•	•	•	•	•	•	•	•	•	•	•	•	•	•	•
32	500	•	•	•	•	•	•	•	•	•	•	•	•	•	•	•	•	•	•
38	750	•	•	•	•	•	•	•	•	•	•	•	•	•	•	•	•	•	•
50	1500	•	•	•	•	•	•	•	•	•	•	•	•	•	•	•	•	•	•
63	2000	•	•	•	•	•	•	•	•	•	•	•	•	•	•	•	•	•	•
75	3000	•	•	•	•	•	•	•	•	•	•	•	•	•	•	•	•	•	•
95	5000	•	•	•	•	•	•	•	•	•	•	•	•	•	•	•	•	•	•
120	9000			•	•	•	•	•	•	•	•	•	•	•	•	•	•	•	•

Maximum number of cycles per minute without lubrication  
Numero massimo di cicli/minuto senza lubrificazione

## MSML

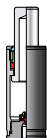

Ø mm	daN	STROKE / CORSA mm																	
		5	10	13	15	20	25	32	38	45	50	56	63	75	80	100	125	160	200
16	100		•		•		•		•										
19	170		•		•		•		•										
25	360		•		•		•		•										

Maximum number of cycles per minute without lubrication  
Numero massimo di cicli/minuto senza lubrificazione

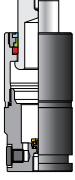

Ø mm	 daN	STROKE / CORSA mm																	
		5	10	13	15	20	25	32	38	45	50	56	63	75	80	100	125	160	200
<b>CX</b>	19	150																	
	25	300																	
	32	500																	
	38	750																	
	50	1500																	
	63	2000																	
	75	3000																	
	95	5000																	
	120	9000																	
Maximum number of cycles per minute without lubrication Numero massimo di cicli/minuto senza lubrificazione			625	415	250	160	125	95	75	60	50	35	30						

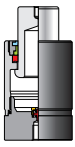

Ø mm	 daN	STROKE / CORSA mm																	
		5	10	13	15	20	25	32	38	45	50	56	63	75	80	100	125	160	200
<b>CSMX</b>	19	150																	
	25	300																	
	32	500																	
	38	750																	
	50	1500																	
	63	2000																	
	75	3000																	
	95	5000																	
	120	9000																	
Maximum number of cycles per minute without lubrication Numero massimo di cicli/minuto senza lubrificazione			625	415	250	160	125	95	75	60	50	35	30						

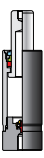

Ø mm	 daN	STROKE / CORSA mm																	
		5	10	13	15	20	25	32	38	45	50	56	63	75	80	100	125	160	200
<b>MICX</b>	25	50																	
	25	100																	
	25	150																	
	25	200																	
	25	300																	
Maximum number of cycles per minute without lubrication Numero massimo di cicli/minuto senza lubrificazione			625	415	250	160	125	75											

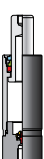

Ø mm	 daN	STROKE / CORSA mm																	
		5	10	13	15	20	25	32	38	45	50	56	63	75	80	100	125	160	200
<b>MCSM</b>	19	80																	
	25	160																	
	Maximum number of cycles per minute without lubrication Numero massimo di cicli/minuto senza lubrificazione		625	415	250	160	125	75											



# STANDARD series

Nitrogen gas springs for press tools, dies and moulds

Cilindri all'azoto per stampi

## TOP

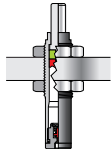

Ø mm	daN	STROKE / CORSA mm															
		5	10	13	15	20	25	32	38	45	50	56	63	75	80	100	125

12	50		•		•														
14	75		•		•														
16	100		•		•														
20	200		•		•														

Maximum number of cycles per minute with lubrication  
Numero massimo di cicli/minuto con lubrificazione

250      165



## TOP

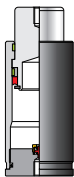

Ø mm	daN	STROKE / CORSA mm																		
		5	10	13	15	20	25	32	38	45	50	56	63	75	80	100	125	160	200	

25	400		•		•		•				•								
32	700		•		•		•				•								
38	1000		•		•		•				•								
50	2000		•		•		•				•								
63	3000		•		•		•				•								
75	4000		•		•		•				•								
95	7000		•		•		•				•								
120	10000		•		•		•				•								

Maximum number of cycles per minute with lubrication  
Numero massimo di cicli/minuto con lubrificazione

250      165      100      50



## VDI 3003

## CVDI

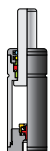

Ø mm	daN	STROKE / CORSA mm																		
		5	10	13	15	20	25	32	38	45	50	56	63	75	80	100	125	160	200	

19	90				•		•		•		•		•		•				
25	200				•		•		•		•		•		•		•		•

Maximum number of cycles per minute with lubrication  
Numero massimo di cicli/minuto con lubrificazione

335      200      130      100      80      65      50      40

Maximum number of cycles per minute without lubrication  
Numero massimo di cicli/minuto senza lubrificazione

200      120      80      60      50      40      30      25



# ISO 11901-1

## CISO

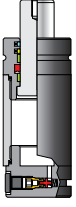

Ø mm	daN	STROKE / CORSA mm																	
		5	10	13	16	20	25	32	38	45	50	56	63	75	80	100	125	160	200
19	100		•		•		•		•		•		•		•		•		•
25	200		•		•		•		•		•		•		•		•		•
32	150		•		•		•		•		•		•		•		•		•
38	250		•	•	•		•		•		•		•	•	•		•		•
45	500						•				•				•				•
50	750			•			•		•		•		•	•	•		•	•	•
75	1500			•			•		•		•		•	•	•		•	•	•
95	3000			•			•		•		•		•	•	•		•	•	•
120	5000			•			•		•		•		•	•	•		•	•	•
150	7500			•			•		•		•		•	•	•		•	•	•
Maximum number of cycles per minute with lubrication Numero massimo di cicli/minuto con lubrificazione			500	385	315		200		130		100		80	70	65		50	40	30
Maximum number of cycles per minute without lubrication Numero massimo di cicli/minuto senza lubrificazione			300	230	190		120		80		60		50	40	40		30	25	20



## CF

**DISCONTINUED  
FOOD PRODUZIONE**



Ø mm	daN	STROKE / CORSA mm																		
		5	10	13	15	20	25	32	38	45	50	56	63	75	80	100	125	160	200	
50	1500		•				•		•		•		•		•		•		•	
63	2000		•				•		•		•		•		•		•		•	
75	3000		•				•		•		•		•		•		•		•	
95	5000						•		•		•		•		•		•		•	
120	9000						•		•		•		•		•		•		•	
Maximum number of cycles per minute with lubrication Numero massimo di cicli/minuto con lubrificazione			500				200		130		100		80		65		50	40	30	25
Maximum number of cycles per minute without lubrication Numero massimo di cicli/minuto senza lubrificazione			300				120		80		60		50		40		30	25	20	15



## CSMF

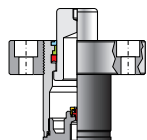

Ø mm	daN	STROKE / CORSA mm																		
		5	10	13	15	20	25	32	38	45	50	56	63	75	80	100	125	160	200	
50	1500		•				•		•		•		•		•		•		•	
63	2000		•				•		•		•		•		•		•		•	
75	3000		•				•		•		•		•		•		•		•	
95	5000						•		•		•		•		•		•		•	
120	9000						•		•		•		•		•		•		•	
Maximum number of cycles per minute with lubrication Numero massimo di cicli/minuto con lubrificazione			500				200		130		100		80		65		50	40	30	25
Maximum number of cycles per minute without lubrication Numero massimo di cicli/minuto senza lubrificazione			300				120		80		60		50		40		30	25	20	15



# STANDARD series

Nitrogen gas springs for press tools, dies and moulds

Cilindri all'azoto per stampi

Ø mm	daN	STROKE / CORSA mm																	
		5	10	13	15	20	25	32	38	45	50	56	63	75	80	100	125	160	200
38	750																		
		500	335	200	130	100	65												
		300	200	120	80	60	40												

Ø mm	daN	STROKE / CORSA mm																		
		5	10	13	15	20	25	32	38	45	50	56	63	75	80	100	125	160	200	250
38	750																			
		500	335	200	130	100	80	65	50											
		300	200	120	80	60	50	40	30											

Ø mm	daN	STROKE / CORSA mm																		
		5	10	13	15	20	25	32	38	45	50	56	63	75	80	100	125	160	200	250
19	100																			
25	200																			
32	350																			
38	500																			
50	1000																			
63	1500																			
75	2500																			
95	4000																			
120	6500																			

Maximum number of cycles per minute with lubrication  
Numero massimo di cicli/minuto con lubrificazione

The maximum number of cycles per minute depends on the specific application, which has to be approved by our technical office  
Il numero massimo di cicli/minuto dipende dall'applicazione specifica, che deve essere approvata dal nostro ufficio tecnico

Ø mm	daN	STROKE / CORSA mm																		
		5	10	13	15	20	25	32	38	45	50	56	63	75	80	100	125	160	200	250
19	100																			
25	200																			
32	350																			
38	500																			
50	1000																			
63	1500																			
75	2500																			
95	4000																			
120	6500																			

Maximum number of cycles per minute with lubrication  
Numero massimo di cicli/minuto con lubrificazione

The maximum number of cycles per minute depends on the specific application, which has to be approved by our technical office  
Il numero massimo di cicli/minuto dipende dall'applicazione specifica, che deve essere approvata dal nostro ufficio tecnico



# CRAL



Ø mm	daN	STROKE / CORSA mm																		
		5	10	13	15	20	25	32	38	45	50	56	63	75	80	100	125	160	200	250
50	1000		•				•		•		•		•		•	•				
63	1500		•				•		•		•		•		•	•				
75	2500		•				•		•		•		•		•	•				
95	4000						•		•		•		•		•	•				
120	6500						•		•		•		•		•	•				

Maximum number of cycles per minute with lubrication  
 Numero massimo di cicli/minuto con lubrificazione

The maximum number of cycles per minute depends on the specific application, which has to be approved by our technical office  
 Il numero massimo di cicli/minuto dipende dall'applicazione specifica, che deve essere approvata dal nostro ufficio tecnico

# OV

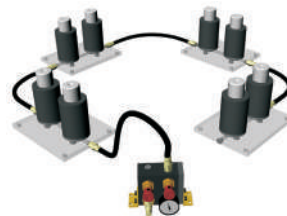

Maximum number of cycles per minute: refer to the original series from which the corresponding OV-type series is derived (for example: for the CSXOV series, see the CSX series)

Numero massimo di cicli/minuto: riferirsi alla serie originale dalla quale la corrispondente serie OV è derivata (per esempio: per la serie CSXOV, si veda la serie CSX)



Ø mm	daN	STROKE / CORSA mm								
		10	20	30	40	50	60	70	80	100
16	42	•	•	•	•	•	•	•	•	•
24	170	•	•	•	•	•	•	•	•	•
		500	250	160	125	100	80	70	60	50

Maximum number of cycles per minute without lubrication  
 Numero massimo di cicli/minuto senza lubrificazione

# EG

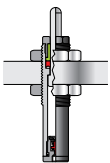

Ø mm	daN	STROKE / CORSA mm					
		10	15	20	30	40	50
12	2	•					
12	4	•					
16	4	•	•	•	•	•	•
16	8	•	•	•	•	•	•
24	10		•				
24	20		•				

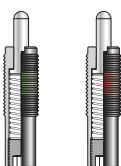

# EM



# Nitrogen gas springs for press tools, dies and moulds

## Production program

### NITROGEN GAS SPRINGS FOR PRESS TOOLS, DIES AND MOULDS:

- » 7 series of self-contained gas springs with WIPERTECH and NANOTECH2 technologies: CSX, SMLX, MSML, CX, CSMX, MICX, MCSM;
  - » 3 other series of self-contained gas springs: TOP, CISO, CVDI;
  - » linkable gas springs for open system connection;
  - » gas springs without valve for connection to plate (OV);
  - » gas springs for MANIFOLD systems;
  - » high temperature gas springs (up to 200°C / 392°F);
  - » slow-return gas springs on request;
  - » timed gas springs on request;
  - » special gas springs on request;
  - » lifters charged with nitrogen (EG).
- » lifters with wire spring (EM).

### CILINDRI ALL'AZOTO PER STAMPI:

- » 7 serie di cilindri autonomi con tecnologie WIPERTECH e NANOTECH2: CSX, SMLX, MSML, CX, CSMX, MICX, MCSM;
  - » 3 altre serie di cilindri autonomi: TOP, CISO, CVDI;
  - » cilindri collegabili a sistema;
  - » cilindri senza valvola per collegamento a piastra (OV);
  - » cilindri per piastra forata (MANIFOLD);
  - » cilindri per alta temperatura (fino a 200°C / 392°F);
  - » cilindri rallentati a richiesta;
  - » cilindri temporizzati a richiesta;
  - » cilindri speciali a richiesta;
  - » espulsori caricati con azoto (EG).
- » espulsori a molla (EM).



# Nano technology series

Nitrogen gas springs for press tools, dies and moulds / *Cilindri all'azoto per stampi*

WIPESTECH

NANOTECH2



## CSX

**THE COMPACT POWER:** as a rule, the CSX models generate the highest available force, up to +50% in comparison with the other nano-technology series and up to 4 times the force of ISO 11901-1 standard models (diameter being the same).

**WHAT'S NEW:** upgraded with the new WIPESTECH and NANOTECH2 nano-technologies. New 2XCSX32 models with diameter 32 mm and increased force are available in addition to the CSX32 models. New stroke lengths available for all diameters.

**FOR THE DIE MAKER:** gas springs with reduced diameters allow to manufacture more compact press dies, cutting all your costs in a drastic way.

**FOR THE DIE USER:** gas springs with a long service life and high working cycles per minute allow to drastically cut the production costs, die maintenance costs and production stops.

**SELF-LUBRICATED** for millions of working cycles thanks to the nano-technologies (patent pending).

**PROTECTED AGAINST CONTAMINANTS** with WIPESTECH protective wiper ring.

**RECOMMENDED** as the first choice for all projects and applications, thanks to the most advanced technology and the highest available forces.

**THE NEW MODELS WILL BE SUPPLIED ONLY WHEN THE OLD ONES ARE OUT OF STOCK.**

**I COMPATTOPOTENTI:** a parità di diametro sviluppano generalmente la forza in assoluto più alta, fino al 50% in più rispetto ai modelli delle altre serie con nano-tecnologie e fino a 4 volte quella dei modelli standard ISO 11901-1.

**NOVITÀ:** aggiornata con le nuove nano-tecnologie WIPESTECH e NANOTECH2. Disponibili i nuovi modelli 2XCSX32, con diametro 32 mm e forza maggiorata, in aggiunta ai già presenti modelli CSX32. Nuove corse disponibili per tutti i diametri.

**PER LO STAMPISTA:** cilindri con diametro minore permettono la realizzazione di stampi più compatti, riducendo notevolmente tutti i vostri costi.

**PER L'UTILIZZATORE:** cilindri con lunga durata ed elevati cicli di lavoro al minuto permettono la drastica riduzione dei costi di produzione, dei costi di manutenzione sugli stampi e dei fermi macchina.

**AUTOLUBRIFICATI** per milioni di cicli grazie alle nano-tecnologie (in corso di brevetto).

**PROTETTI DA CONTAMINANTI** con anello raschiastelo di protezione WIPESTECH.

**CONSIGLIATI** come prima scelta per tutti i progetti e applicazioni, grazie alla tecnologia più avanzata e alle forze in assoluto più alte.

**I NUOVI MODELLI SARANNO FORNITI SOLO AD ESAURIMENTO SCORTE DEI VECCHI.**

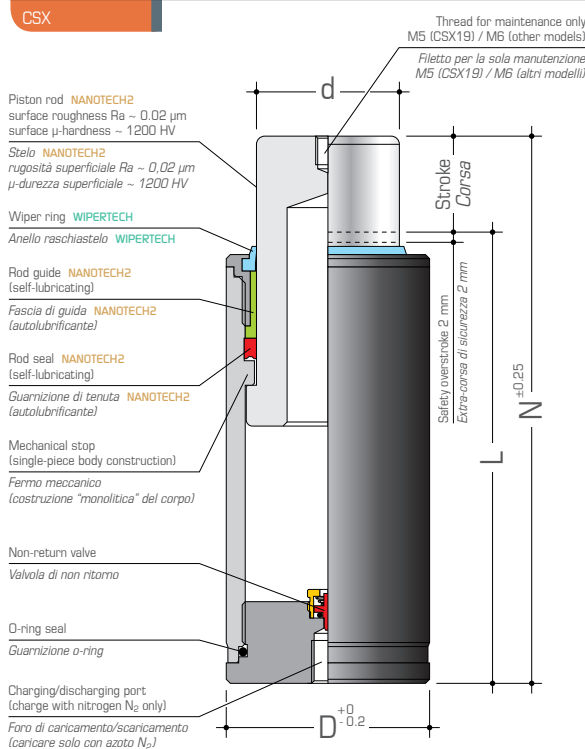

### Fixing possibilities

(see also our "Accessories for nitrogen gas springs for dies" catalogue)

### Fissaggi possibili

(vedi anche il nostro catalogo "Accessori per cilindri all'azoto per stampi")

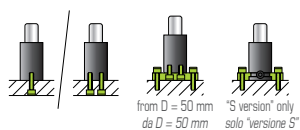

### TECHNICAL NOTES

#### Important use instructions and maximum number of cycles per minute on pages 10-17.

For accessories and other mountings, see the "Accessories for nitrogen gas springs for dies" catalogue. Different stroke lengths on request.

The CS models are replaceable with the CSX models.

#### "S" VERSION

With fixing groove and G1/8 side port, linkable to open system, from D = 50 mm.

- » L and N dimensions: + 20 mm
- » Add an -S to order them
- Example: no. 8 pcs. CSX50-50-S

### NOTE TECNICHE

#### Importanti istruzioni d'uso e numero massimo di cicli/minuto alle pagine 10-17.

Per accessori e altri montaggi, consultare il catalogo "Accessori per cilindri all'azoto per stampi". Corse di lavoro diverse a richiesta.

I modelli CS sono sostituibili con i modelli CSX.

#### VERSIONE "S"



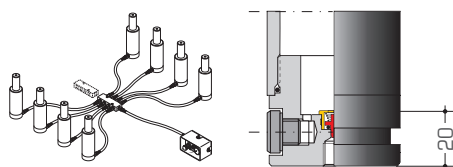

Da D = 50 mm, scanalatura di fissaggio e foro laterale G1/8, per collegamento a sistema.

- » Quote L e N: + 20 mm
- » Per ordinarli, aggiungere una -S
- Esempio: n° 8 CSX50-50-S

### "S" version



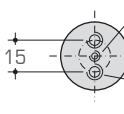
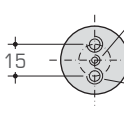
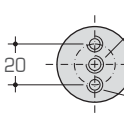
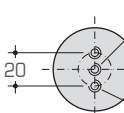
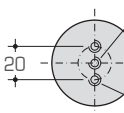
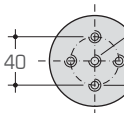
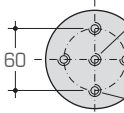

MODEL MODELLO	MAX STROKE mm CORSIA MAX mm	L mm	N mm	D mm	d mm	 bar	 daN	 daN	GAS SPRING BASE BASE DEL CILINDRO	
CSX19-10	10	65	75	19	10	191	150	200	 <p>M6 x 8 for charging/discharging per il caricamento/scaricamento for fixing per il fissaggio</p>	
15	15	70	85					210		
20	20	75	95					220		
25	25	80	105					230		
32	32	88	120					230		
38	38	97	135					240		
45	45	105	150					240		
50	50	110	160					240		
56	56	119	175					240		
63	63	127	190					240		
80	80	140	220	250						
CSX25-10	10	65	75	25	14	195	300	430	 <p>M6 x 10 for charging/discharging per il caricamento/scaricamento for fixing per il fissaggio</p>	
15	15	70	85					450		
20	20	75	95					480		
25	25	80	105					500		
32	32	88	120					520		
38	38	97	135					530		
45	45	105	150					540		
50	50	110	160					550		
56	56	119	175					550		
63	63	127	190					550		
80	80	145	225	580						
CSX32-10	10	65	75	32	18	197	500	680	 <p>M4 for charging/discharging per il caricamento/scaricamento M6 x 9 (2x) for fixing per il fissaggio</p>	
15	15	70	85					770		
20	20	75	95					800		
25	25	80	105					840		
32	32	88	120					870		
38	38	97	135					870		
45	45	105	150					890		
50	50	110	160					900		
56	56	119	175					910		
63	63	132	195					910		
80	80	150	230	920						
New model!	2XCSX32-10	10	65	75	32	20	210	660	950	 <p>M4 for charging/discharging per il caricamento/scaricamento M6 x 9 (2x) for fixing per il fissaggio</p>
	15	15	70	85					1000	
	20	20	75	95					1050	
	25	25	80	105					1100	
	32	32	88	120					1150	
	38	38	97	135					1150	
	45	45	105	150					1160	
	50	50	110	160					1170	
56	56	119	175	1180						
63	63	132	195	1190						
80	80	150	230	1200						
CSX38-10	10	65	75	38	25	205	1000	1530	 <p>M8 for charging/discharging per il caricamento/scaricamento M6 x 10 (2x) for fixing per il fissaggio</p>	
15	15	70	85					1730		
20	20	75	95					1880		
25	25	80	105					2000		
32	32	88	120					2080		
38	38	97	135					2090		
45	45	105	150					2100		
50	50	110	160					2110		
56	56	119	175					2130		
63	63	142	205					2140		
80	80	160	240	2150						
CSX50-10	10	80	90	50	35	209	2000	3000	 <p>M8 for charging/discharging per il caricamento/scaricamento M8 x 12 (2x) for fixing per il fissaggio</p>	
15	15	100	115					3050		
20	20	105	125					3100		
25	25	110	135					3200		
32	32	118	150					3500		
38	38	127	165					3600		
45	45	135	180					3700		
50	50	140	190					3800		
56	56	149	205					3900		
63	63	157	220					4100		
80	80	175	255	4400						
CSX63-10	10	85	95	63	45	189	3000	3900	 <p>M8 for charging/discharging per il caricamento/scaricamento M8 x 12 (2x) for fixing per il fissaggio</p>	
15	15	100	115					4000		
20	20	105	125					4200		
25	25	110	135					4400		
32	32	118	150					4600		
38	38	127	165					4700		
45	45	135	180					4900		
50	50	140	190					5000		
63	63	157	220					5200		
80	80	175	255					5500		
CSX75-10	10	90	100	75	58	190	5000	6400	 <p>M8 for charging/discharging per il caricamento/scaricamento M8 x 12 (4x) for fixing per il fissaggio</p>	
15	15	110	125					6500		
25	25	120	145					7000		
38	38	137	175					7700		
50	50	150	200					8100		
63	63	177	240					8200		
80	80	195	275	8500						
CSX95-10	10	100	110	95	75	182	8000	10900	 <p>M8 for charging/discharging per il caricamento/scaricamento M8 x 14 (4x) for fixing per il fissaggio</p>	
15	15	120	135					11100		
25	25	130	155					11800		
38	38	147	185					12600		
50	50	165	215					12900		
63	63	192	255					13200		
80	80	210	290					13600		
100	100	240	340					13900		

# Nano technology series

Nitrogen gas springs for press tools, dies and moulds / *Cilindri all'azoto per stampi*



PATENTS PENDING

## SMLX

THE SHORTEST AND MOST POWERFUL SINCE 2001: extremely compact with minimum height clearance and with forces up to 3 times the ones of ISO 11901-1 standard models (diameter being the same).

WHAT'S NEW: upgraded with the new WIPESTECH and NANOTECH2 nano-technologies. New SMLX120 models available, with diameter 120 mm and an initial force of 9000 daN. New stroke lengths available for all diameters. FOR THE DIE MAKER: gas springs with reduced diameters and reduced lengths allow to manufacture more compact press dies, cutting all your costs in a drastic way.

FOR THE DIE USER: gas springs with a long service life and high working cycles per minute allow to drastically cut the production costs, die maintenance costs and production stops. SELF-LUBRICATED for millions of working cycles thanks to the nano-technologies (patent pending). PROTECTED AGAINST CONTAMINANTS with WIPESTECH protective wiper ring. RECOMMENDED for all projects and applications, thanks to the most advanced technology, reduced dimensions and high forces.

THE NEW MODELS WILL BE SUPPLIED ONLY WHEN THE OLD ONES ARE OUT OF STOCK.

IL PIÙ BASSO E PIÙ POTENTE DAL 2001: estremamente compatti con minimo ingombro in altezza, con forza fino a 3 volte quella dei corrispondenti modelli standard ISO 11901-1.

NOVITÀ: aggiornata con le nuove nano-tecnologie WIPESTECH e NANOTECH2. Disponibili i nuovi modelli SMLX120, con diametro 120 mm e forza iniziale di 9000 daN. Nuove corse disponibili per tutti i diametri.

PER LO STAMPISTA: cilindri con diametro ed altezza minori permettono la realizzazione di stampi più compatti, riducendo notevolmente tutti i vostri costi.

PER L'UTILIZZATORE: cilindri con lunga durata ed elevati cicli di lavoro al minuto permettono la drastica riduzione dei costi di produzione, dei costi di manutenzione sugli stampi e dei fermi macchina.

AUTOLUBRIFICATI per milioni di cicli grazie alle nano-tecnologie (in corso di brevetto).

PROTETTI DA CONTAMINANTI con anello raschiastelo di protezione WIPESTECH.

CONSIGLIATI per tutti i progetti e applicazioni, grazie alla tecnologia più avanzata, alle dimensioni ridotte e alle forze elevate.

I NUOVI MODELLI SARANNO FORNITI SOLO AD ESAURIMENTO SCORTE DEI VECCHI.

### Fixing possibilities

(see also our "Accessories for nitrogen gas springs for dies" catalogue)

### Fissaggi possibili

(vedi anche il nostro catalogo "Accessori per cilindri all'azoto per stampi")

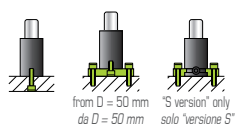

### "S" VERSION

With fixing groove and G1/8 side port, linkable to open system, from D = 50 mm.

» **L and N dimensions: + 20 mm**

» Add an **-S** to order them

Example: no. 8 pcs. SMLX50-50-**S**

### VERSIONE "S"

Da D = 50 mm, scanalatura di fissaggio e foro laterale G1/8, per collegamento a sistema.

» **Quote L e N: + 20 mm**

» Per ordinarli, aggiungere una **-S**

Esempio: n° 8 SMLX50-50-**S**

### "S" VERSION

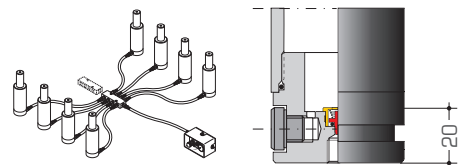

### SMLX

Piston rod NANOTECH2  
surface roughness Ra ~ 0.02 µm  
surface µ-hardness ~ 1200 HV

Stelo NANOTECH2  
rugosità superficiale Ra ~ 0.02 µm  
µ-durezza superficiale ~ 1200 HV

Wiper ring WIPESTECH

Anello raschiastelo WIPESTECH

Rod guide NANOTECH2  
(self-lubricating)

Fascia di guida NANOTECH2  
(autolubrificante)

Rod seal NANOTECH2  
(self-lubricating)

Guarnizione di tenuta NANOTECH2  
(autolubrificante)

Mechanical stop  
(single-piece body construction)

Fermo meccanico  
(costruzione "monolitica" del corpo)

Non-return valve

Valvola di non ritorno

O-ring seal

Guarnizione o-ring

Charging/discharging port  
(charge with nitrogen N<sub>2</sub> only)

Foro di caricamento/scaricamento  
(caricare solo con azoto N<sub>2</sub>)

Filetto M6 per la sola manutenzione

Filetto M6 per la sola manutenzione

Filetto M6 per la sola manutenzione

Filetto M6 per la sola manutenzione

Filetto M6 per la sola manutenzione

Filetto M6 per la sola manutenzione

Filetto M6 per la sola manutenzione

Filetto M6 per la sola manutenzione

Filetto M6 per la sola manutenzione

Filetto M6 per la sola manutenzione

Filetto M6 per la sola manutenzione

Filetto M6 per la sola manutenzione

Filetto M6 per la sola manutenzione

Filetto M6 per la sola manutenzione

Filetto M6 per la sola manutenzione

Filetto M6 per la sola manutenzione

Filetto M6 per la sola manutenzione

Filetto M6 per la sola manutenzione

Filetto M6 per la sola manutenzione

Filetto M6 per la sola manutenzione

Filetto M6 per la sola manutenzione

Filetto M6 per la sola manutenzione

Filetto M6 per la sola manutenzione

Filetto M6 per la sola manutenzione

Filetto M6 per la sola manutenzione

Filetto M6 per la sola manutenzione

Filetto M6 per la sola manutenzione

Filetto M6 per la sola manutenzione

Filetto M6 per la sola manutenzione

Filetto M6 per la sola manutenzione

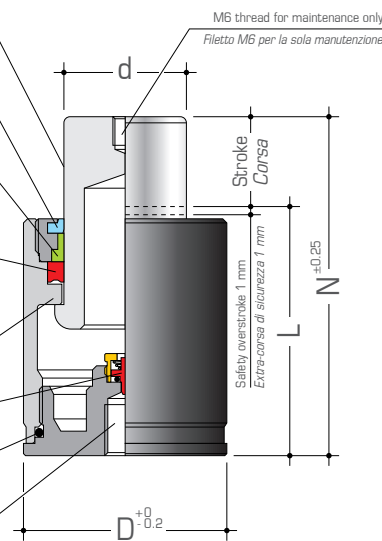

### TECHNICAL NOTES

### Important use instructions and maximum number of cycles per minute on pages 10-17.

For accessories and other mountings, see the "Accessories for nitrogen gas springs for dies" catalogue. Different stroke lengths on request.

The SML models are replaceable with the SMLX models.

### NOTE TECNICHE











### Importanti istruzioni d'uso e numero massimo di cicli/minuto alle pagine 10-17.

Per accessori e altri montaggi, consultare il catalogo "Accessori per cilindri all'azoto per stampi". Corse di lavoro diverse a richiesta.

I modelli SML sono sostituibili con i modelli SMLX.

MODEL MODELLO	MAX STROKE CORSA MAX	L	N	D	d	bar	daN	daN	GAS SPRING BASE BASE DEL CILINDRO
SMLX25-05	5	35	40	25	14	195	300	450	M6 x 8 for charging/discharging for fixing per il caricamento/scaricamento per il fissaggio
10	10	40	50						
13	13	43	56						
15	15	45	60						
20	20	50	70						
25	25	55	80						
32	32	62	94						
38	38	68	106						
50	50	80	130						
63	63	93	156						
75	75	105	180						
80	80	110	190						
100	100	130	230						
125	125	155	280						

SMLX25 models on page 22 / Modelli SMLX25 a pagina 22

MODEL MODELLO	MAX STROKE mm CORSA MAX mm	L mm	N mm	D mm	d mm	 bar	 daN	 daN	GAS SPRING BASE BASE DEL CILINDRO	
SMLX32-05	5	35	40	32	18	196	500	750	 <p>M6 x 8 for charging/discharging for fixing per il caricamento/scaricamento per il fissaggio</p>	
10	10	40	50							790
13	13	43	56							830
15	15	45	60							850
20	20	50	70							870
25	25	55	80							880
32	32	62	94							880
38	38	68	106							890
45	45	75	120							900
50	50	80	130							900
56	56	86	142							910
63	63	93	156							930
75	75	105	180							930
80	80	110	190	930						
100	100	130	230	940						
125	125	155	280	940						
SMLX38-05	5	35	40	38	22	197	750	1050	 <p>M8 x 12 for charging/discharging for fixing per il caricamento/scaricamento per il fissaggio</p>	
10	10	40	50							1200
13	13	43	56							1250
15	15	45	60							1270
20	20	50	70							1280
25	25	55	80							1350
32	32	62	94							1370
38	38	68	106							1370
45	45	75	120							1400
50	50	80	130							1410
56	56	86	142							1420
63	63	93	156							1430
75	75	105	180							1440
80	80	110	190	1440						
100	100	130	230	1440						
125	125	155	280	1450						
SMLX50-05	5	40	45	50	30	212	1500	2600	 <p>M10 x 12 for charging/discharging for fixing per il caricamento/scaricamento per il fissaggio</p>	
10	10	45	55							2800
13	13	48	61							2900
15	15	50	65							3000
20	20	55	75							3040
25	25	60	85							3050
32	32	67	99							3060
38	38	73	111							3070
45	45	80	125							3080
50	50	85	135							3090
56	56	91	147							3100
63	63	98	161							3110
75	75	110	185							3120
80	80	120	200	3130						
100	100	135	235	3150						
125	125	160	285	3200						
SMLX63-05	5	40	45	63	40	159	2000	3000	 <p>M10 x 15 for charging/discharging for fixing per il caricamento/scaricamento per il fissaggio</p>	
10	10	45	55							3600
15	15	50	65							3800
20	20	55	75							3850
25	25	60	85							3880
32	32	67	99							3890
38	38	73	111							3900
50	50	85	135							3910
63	63	98	161							3930
75	75	110	185							3950
80	80	120	200							3980
100	100	135	235							4000
125	125	160	285							4020
SMLX75-05	5	45	50	75	45	189	3000	4400	 <p>M12 x 14 for charging/discharging for fixing per il caricamento/scaricamento per il fissaggio</p>	
10	10	50	60							5000
15	15	55	70							5400
20	20	60	80							5450
25	25	65	90							5500
32	32	72	104							5550
38	38	77	115							5600
50	50	90	140							5650
63	63	103	166							5700
75	75	115	190							5750
80	80	125	205							5800
100	100	145	245							5900
125	125	170	295							6000
SMLX95-05	5	55	60	95	58	189	5000	7200	 <p>M12 x 19 for charging/discharging for fixing per il caricamento/scaricamento per il fissaggio</p>	
10	10	60	70							8000
15	15	65	80							8500
20	20	70	90							8700
25	25	75	100							8900
32	32	82	114							9000
38	38	88	126							9050
50	50	100	150							9100
63	63	113	176							9200
75	75	125	200							9250
80	80	130	210							9300
100	100	150	250							9350
125	125	175	300							9400
SMLX120-15	15	75	90	120	75	204	9000	14000	 <p>M16 x 24 for charging/discharging for fixing per il caricamento/scaricamento per il fissaggio</p>	
20	20	80	100							14500
25	25	85	110							15000
32	32	92	124							15500
38	38	98	136							15700
50	50	110	160							16000
63	63	123	186							16300
75	75	135	210							16500
80	80	140	220							16600
100	100	160	260							16800
125	125	185	310	16900						

New modelli

• No threaded hole on the piston rod / Sullo stelo non è presente il foro filettato

# Nano technology series

Nitrogen gas springs for press tools, dies and moulds / *Cilindri all'azoto per stampi*

WIPERTECH

NANOTECH2



PATENTS PENDING

## MSML

New model!

Gas springs with compact dimensions (available diameters: 16 mm, 19 mm and 25 mm), with the highest available forces (even in comparison with the CSX series, diameter being the same).

WHAT'S NEW: new series in the catalogue, with the new WIPERTECH and NANOTECH2 nano-technologies.

FOR THE DIE MAKER: gas springs with reduced diameters and reduced lengths allow to manufacture more compact press dies, cutting all your costs in a drastic way.

FOR THE DIE USER: gas springs with a long service life and high working cycles per minute allow to drastically cut the production costs, die maintenance costs and production stops.

SELF-LUBRICATED for millions of working cycles thanks to the nano-technologies (patent pending).

PROTECTED AGAINST CONTAMINANTS with WIPERTECH protective wiper ring.

RECOMMENDED when smaller diameters and highest forces are required.

*Cilindri di dimensioni ridotte, disponibili nei diametri 16 mm, 19 mm e 25 mm, con le forze in assoluto più alte (anche rispetto alla serie CSX a parità di diametro).*

*NOVITÀ: nuova serie a catalogo, dotata delle nuove nano-tecnologie WIPERTECH e NANOTECH2.*

*PER LO STAMPISTA: cilindri con diametro ed altezza minori permettono la realizzazione di stampi più compatti, riducendo notevolmente tutti i vostri costi.*

*PER L'UTILIZZATORE: cilindri con lunga durata ed elevati cicli di lavoro al minuto permettono la drastica riduzione dei costi di produzione, dei costi di manutenzione sugli stampi e dei fermi macchina.*

*AUTOLUBRIFICATI per milioni di cicli grazie alle nano-tecnologie (in corso di brevetto).*

*PROTETTI DA CONTAMINANTI con anello raschiastelo di protezione WIPERTECH.*

*CONSIGLIATI per applicazioni in cui sono richiesti diametri estremamente contenuti e forze elevate.*

### Fixing possibilities

(see also our "Accessories for nitrogen gas springs for dies" catalogue)

### Fissaggi possibili

(vedi anche il nostro catalogo "Accessori per cilindri all'azoto per stampi")



### MSML

Piston rod NANOTECH2  
surface roughness Ra ~ 0.02 µm  
surface µ-hardness ~ 1200 HV

Stelo NANOTECH2  
rugosità superficiale Ra ~ 0.02 µm  
µ-durezza superficiale ~ 1200 HV

Wiper ring WIPERTECH  
Anello raschiastelo WIPERTECH

Rod guide NANOTECH2  
(self-lubricating)

Fascia di guida NANOTECH2  
(autolubrificante)

Rod seal NANOTECH2  
(self-lubricating)

Guarnizione di tenuta NANOTECH2  
(autolubrificante)

Mechanical stop  
(single-piece body construction)

Fermo meccanico  
(costruzione "monolitica" del corpo)

Non-return valve

Valvola di non ritorno

O-ring seal

Guarnizione o-ring

Charging/discharging port  
(charge with nitrogen N<sub>2</sub> only)

Foro di caricamento/scaricamento  
(caricare solo con azoto N<sub>2</sub>)

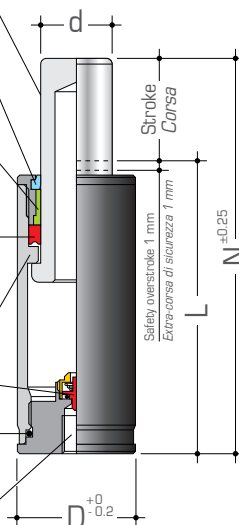

### TECHNICAL NOTES







#### Important use instructions and maximum number of cycles per minute on pages 10-17.

For accessories and other mountings, see the "Accessories for nitrogen gas springs for dies" catalogue.

### NOTE TECNICHE

#### Importanti istruzioni d'uso e numero massimo di cicli/minuto alle pagine 10-17.

Per accessori e altri montaggi, consultare il catalogo "Accessori per cilindri all'azoto per stampi".

MODEL MODELLO	MAX STROKE mm CORSA MAX mm	L mm	N mm	D mm	d mm	 bar	 daN	 daN	GAS SPRING BASE BASE DEL CILINDRO
MSML16-10	10	45	55	16	8	199	100	140	 <p>M5 x 7 for charging/discharging for fixing per il caricamento/scaricamento per il fissaggio</p>
15	15	50	65					150	
25	25	60	85					160	
38	38	73	111					170	
MSML19-10	10	45	55	19	10	216	170	240	 <p>M5 x 7 for charging/discharging for fixing per il caricamento/scaricamento per il fissaggio</p>
15	15	50	65					260	
25	25	60	85					280	
38	38	73	111					300	
MSML25-10	10	45	55	25	15	204	360	550	 <p>M6 x 8 for charging/discharging for fixing per il caricamento/scaricamento per il fissaggio</p>
15	15	50	65					600	
25	25	60	85					650	
38	38	73	111					700	

# Nano technology series

Nitrogen gas springs for press tools, dies and moulds / *Cilindri all'azoto per stampi*

WIPERTECH

NANOTECH2



PATENTS PENDING

## Fixing possibilities

(see also our "Accessories for nitrogen gas springs for dies" catalogue)

## Fissaggi possibili

(vedi anche il nostro catalogo "Accessori per cilindri all'azoto per stampi")

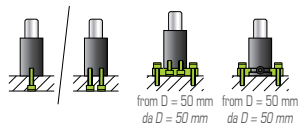

## HOW TO ORDER

### No. 8 pcs. CX38-50 750daN

No. 8 nitrogen gas springs series CX, D = 38 mm, stroke length = 50 mm, initial force = 750 daN.

**ATTENTION: specify the required initial force.**

## ESEMPIO D'ORDINE

### No. 8 CX38-50 750daN

N° 8 cilindri all'azoto serie CX, D = 38 mm, corsa = 50 mm, forza iniziale = 750 daN.

**ATTENZIONE: specificare la forza iniziale desiderata.**

# CX

CX series replaces the previous C series. Available with the same diameters and forces as the SMLX series, the CX gas springs have a less compact length but longer stroke lengths are available (starting from diameter 50 mm).

**WHAT'S NEW:** upgraded with the new WIPERTECH and NANOTECH2 nano-technologies.

**SELF-LUBRICATED** for millions of working cycles thanks to the nano-technologies (patent pending).

**PROTECTED AGAINST CONTAMINANTS** with WIPERTECH protective wiper ring.

**RECOMMENDED** when the required stroke lengths are not available for CSX and SMLX series.

**THE NEW MODELS WILL BE SUPPLIED ONLY WHEN THE OLD ONES ARE OUT OF STOCK.**

*Sostituisce la precedente serie C. Disponibile negli stessi diametri e stesse forze della serie SMLX, presenta un ingombro in altezza più elevato ma è disponibile con corse di lavoro più lunghe (a partire dal diametro 50 mm).*

*NOVITÀ: aggiornata con le nuove nano-tecnologie WIPERTECH e NANOTECH2.*

*AUTOLUBRIFICATI per milioni di cicli grazie alle nano-tecnologie (in corso di brevetto).*

*PROTETTI DA CONTAMINANTI con anello raschiastelo di protezione WIPERTECH.*

*CONSIGLIATI per applicazioni con corse di lavoro che non sono disponibili per le serie CSX e SMLX.*

**I NUOVI MODELLI SARANNO FORNITI SOLO AD ESAURIMENTO SCORTE DEI VECCHI.**

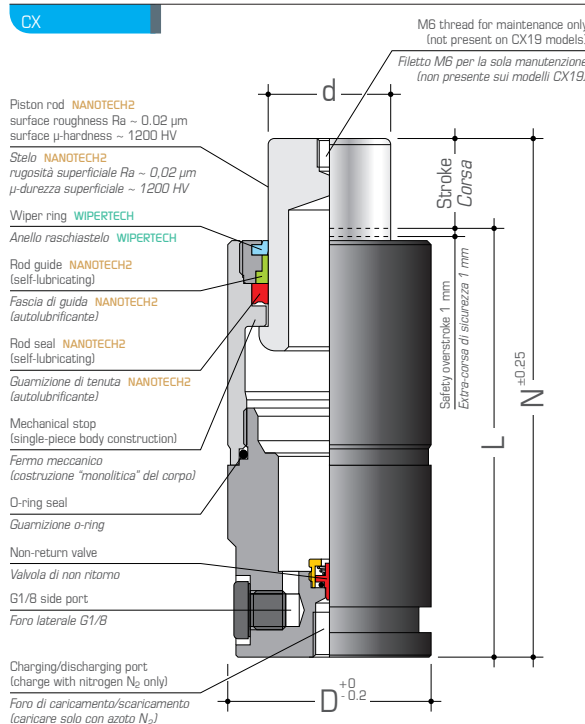

## TECHNICAL NOTES

### Important use instructions and maximum number of cycles per minute on pages 10-17.

For accessories and other mountings, see the "Accessories for nitrogen gas springs for dies" catalogue.

The C models are replaceable with the CX models.

#### ⚠ ATTENTION:

**Rod diameter d = 40 mm for the CX63 models.**

**Rod diameter d = 36 mm for the C63 models.**

## NOTE TECNICHE

### Importanti istruzioni d'uso e numero massimo di cicli/minuto alle pagine 10-17.

Per accessori e altri montaggi, consultare il catalogo "Accessori per cilindri all'azoto per stampi".

I modelli C sono sostituibili con i modelli CX.

#### ⚠ ATTENZIONE:

**Diametro dello stelo d = 40 mm per i modelli CX63.**

**Diametro dello stelo d = 36 mm per i modelli C63.**

## Linkable / Collegabili

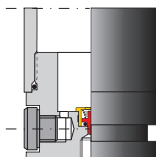
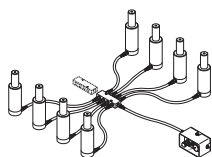









Ready with fixing groove and G1/8 side port, linkable to open system, from D = 50 mm.

**ATTENTION: make sure to fully discharge the gas spring before connecting it to open system (see the instructions supplied together with the charging and discharging set COMPL).**

Pronti, da D = 50 mm, con scanalatura di fissaggio e foro laterale G1/8, per collegamento a sistema.

**ATTENZIONE: assicurarsi di scaricare completamente il cilindro prima di collegarlo a sistema (vedi le istruzioni fornite assieme al set di carico e scarico COMPL).**

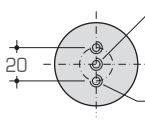

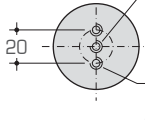
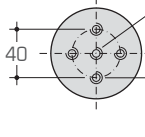
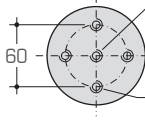
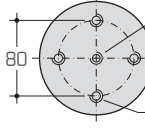
MODEL MODELLO	MAX STROKE mm CORSIA MAX mm	L mm	N mm	D mm	d mm	 bar	 daN	 daN	GAS SPRING BASE BASE DEL CILINDRO
CX19-10	10	70	80	19	10	191	150	190	 M8 x 14 for charging/discharging for fixing per il caricamento/scaricamento per il fissaggio
15	15	75	90					200	
25	25	85	110					220	
38	38	98	136					220	
50	50	110	160					240	
80	80	140	220					250	
CX25-10	10	70	80	25	14	195	300	380	 M8 x 11 for charging/discharging for fixing per il caricamento/scaricamento per il fissaggio
15	15	75	90					400	
25	25	85	110					440	
38	38	98	136					490	
50	50	110	160					500	
80	80	140	220					540	
CX32-10	10	60	70	32	18	196	500	700	 M8 x 8 for charging/discharging for fixing per il caricamento/scaricamento per il fissaggio
15	15	65	80					720	
25	25	75	100					770	
38	38	88	126					790	
50	50	100	150					800	
80	80	130	210					800	
CX38-10	10	65	75	38	22	197	750	980	 M8 x 9 for charging/discharging for fixing per il caricamento/scaricamento per il fissaggio
15	15	70	85					1060	
25	25	80	105					1100	
38	38	93	131					1150	
50	50	105	155					1200	
80	80	140	220					1250	
CX50-10	10	95	105	50	30	212	1500	1900	 M8 for charging/discharging per il caricamento/scaricamento M8 x 12 (2x) for fixing per il fissaggio
25	25	110	135					2150	
38	38	123	161					2250	
50	50	135	185					2320	
63	63	148	211					2430	
80	80	165	245					2430	
100	100	195	295					2500	
125	125	220	345					2520	
160	160	255	415					2550	
200	200	295	495					2600	
CX63-10	10	95	105	63	40 	159	2000	2900	 M8 for charging/discharging per il caricamento/scaricamento M8 x 12 (2x) for fixing per il fissaggio
25	25	110	135					3300	
38	38	123	161					3400	
50	50	135	185					3500	
63	63	148	211					3550	
80	80	165	245					3600	
100	100	185	285					3650	
125	125	220	345					3700	
160	160	255	415					3750	
200	200	295	495					3800	
CX75-10	10	105	115	75	45	189	3000	4200	 M8 for charging/discharging per il caricamento/scaricamento M8 x 12 (4x) for fixing per il fissaggio
25	25	120	145					4700	
38	38	133	171					5000	
50	50	145	195					5100	
63	63	158	221					5200	
80	80	175	255					5300	
100	100	200	300					5400	
125	125	225	350					5500	
160	160	265	425					5600	
200	200	310	510					5800	
CX95-25	25	130	155	95	58	189	5000	7800	 M8 for charging/discharging per il caricamento/scaricamento M8 x 12 (4x) for fixing per il fissaggio
38	38	143	181					8100	
50	50	155	205					8300	
63	63	168	231					8500	
80	80	190	270					8600	
100	100	210	310					8700	
125	125	245	370					8900	
160	160	280	440					9000	
200	200	330	530					9100	
CX120-25	25	140	165	120	75	204	9000	12600	 M8 for charging/discharging per il caricamento/scaricamento M10 x 15 (4x) for fixing per il fissaggio
38	38	153	191					13400	
50	50	165	215					13900	
63	63	178	241					14400	
80	80	195	275					14800	
100	100	215	315					15200	
125	125	250	375					15300	
160	160	290	450					16500	
200	200	340	540					16800	

• Without G1/8 side hole and groove / Senza foro laterale G1/8 e scanalatura

• Available on request / Disponibili a richiesta

 Attention: see note on page 26 /  Attenzione: vedere nota a pag. 26

# Nano technology series

Nitrogen gas springs for press tools, dies and moulds / *Cilindri all'azoto per stampi*



PATENTS PENDING

## CSMX

CSMX series replaces the previous CSM series. Available with the same diameters and forces as the SMLX series, the CSMX gas springs are the second-shortest as far as overall length. Longer stroke lengths are available in comparison with the SMLX series (starting from diameter 50 mm).

WHAT'S NEW: upgraded with the new WIPERTECH and NANOTECH2 nano-technologies.

SELF-LUBRICATED for millions of working cycles thanks to the nano-technologies (patent pending).

PROTECTED AGAINST CONTAMINANTS with WIPERTECH protective wiper ring.

RECOMMENDED when the required stroke lengths are not available for CSX and SMLX series.

THE NEW MODELS WILL BE SUPPLIED ONLY WHEN THE OLD ONES ARE OUT OF STOCK.

Sostituisce la precedente serie CSM. Disponibile negli stessi diametri e stesse forze della serie SMLX, è – dopo di quest'ultima – la serie con ingombro in altezza più contenuto. Rispetto alla serie SMLX, è disponibile con corse di lavoro più lunghe (a partire dal diametro 50 mm).

NOVITÀ: aggiornata con le nuove nano-tecnologie WIPERTECH e NANOTECH2.

AUTOLUBRIFICATI per milioni di cicli grazie alle nano-tecnologie (in corso di brevetto).

PROTETTI DA CONTAMINANTI con anello raschiastelo di protezione WIPERTECH.

CONSIGLIATI per applicazioni con corse di lavoro che non sono disponibili per le serie CSX e SMLX.

I NUOVI MODELLI SARANNO FORNITI SOLO AD ESAURIMENTO SCORTE DEI VECCHI.

### Fixing possibilities

(see also our "Accessories for nitrogen gas springs for dies" catalogue)

### Fissaggi possibili

(vedi anche il nostro catalogo "Accessori per cilindri all'azoto per stampi")

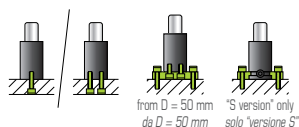

### CSMX

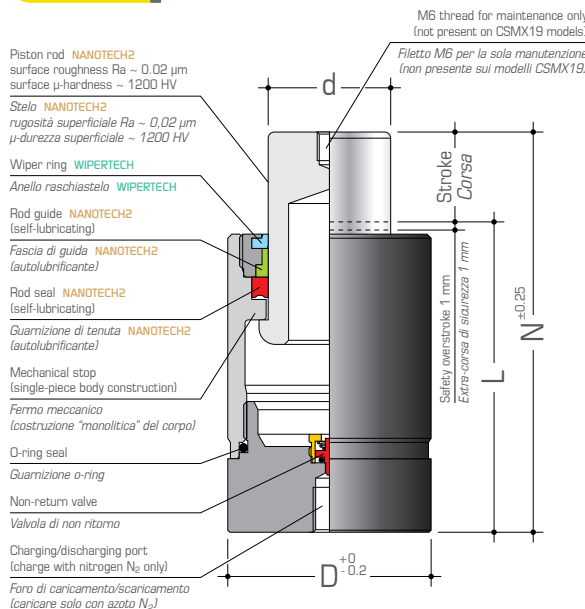

### HOW TO ORDER

### ESEMPIO D'ORDINE

#### No. 8 pcs. CSMX38-50 750daN

No. 8 nitrogen gas springs series CSMX, D = 38 mm, stroke length = 50 mm, initial force = 750 daN.

**ATTENTION: specify the required initial force.**

#### No. 8 CSMX38-50 750daN

N° 8 cilindri all'azoto serie CSMX, D = 38 mm, corsa = 50 mm, forza iniziale = 750 daN.

**ATTENZIONE: specificare la forza iniziale desiderata.**

### TECHNICAL NOTES

#### Important use instructions and maximum number of cycles per minute on pages 10-17.

For accessories and other mountings, see the "Accessories for nitrogen gas springs for dies" catalogue.

The CSM models are replaceable with the CSMX models.

#### ⚠ ATTENTION:

**Rod diameter d = 40 mm for the CSMX63 models.**

**Rod diameter d = 36 mm for the CSM63 models.**

### NOTE TECNICHE

#### Importanti istruzioni d'uso e numero massimo di cicli/minuto alle pagine 10-17.

Per accessori e altri montaggi, consultare il catalogo "Accessori per cilindri all'azoto per stampi".

I modelli CSM sono sostituibili con i modelli CSMX.

#### ⚠ ATTENZIONE:

**Diametro dello stelo d = 40 mm per i modelli CSMX63.**

**Diametro dello stelo d = 36 mm per i modelli CSM63.**

### "S" version

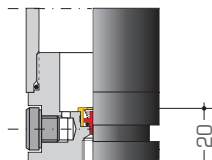
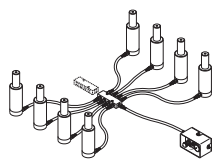

### "S" VERSION

With fixing groove and G1/8 side port, linkable to open system, from D = 50 mm.

» **L and N dimensions: + 20 mm**

» Add an **-S** to order them

Example: no. 8 pcs. CSMX50-50-**S**









### VERSIONE "S"

Da D = 50 mm, scanalatura di fissaggio e foro laterale G1/8, per collegamento a sistema.

» **Quote L e N: + 20 mm**

» Per ordinarli, aggiungere una **-S**

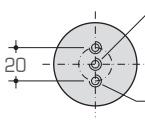
Esempio: n° 8 CSMX50-50-**S**

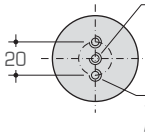
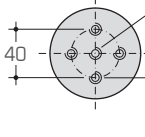
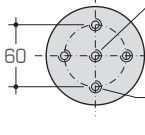
MODEL MODELLO	MAX STROKE mm CORSA MAX mm	L mm	N mm	D mm	d mm	 bar	 daN	 daN	GAS SPRING BASE BASE DEL CILINDRO
CSMX19-10	10	50	60	19	10	191	150	200	 <p>M6 x 8 for charging/discharging for fixing per il caricamento/scaricamento per il fissaggio</p>
15	15	55	70					210	
25	25	65	90					240	
38	38	78	116					240	
50	50	90	140					250	
80	80	120	200					250	
CSMX25-10	10	50	60	25	14	195	300	440	 <p>M6 x 8 for charging/discharging for fixing per il caricamento/scaricamento per il fissaggio</p>
15	15	55	70					510	
25	25	65	90					520	
38	38	78	116					550	
50	50	90	140					560	
80	80	120	200					580	
CSMX32-10	10	55	65	32	18	196	500	710	 <p>M6 x 8 for charging/discharging for fixing per il caricamento/scaricamento per il fissaggio</p>
15	15	60	75					720	
25	25	70	95					760	
38	38	83	121					800	
50	50	95	145					820	
80	80	125	205					830	
CSMX38-10	10	55	65	38	22	197	750	1090	 <p>M8 x 11 for charging/discharging for fixing per il caricamento/scaricamento per il fissaggio</p>
15	15	60	75					1130	
25	25	70	95					1180	
38	38	83	121					1230	
50	50	95	145					1240	
80	80	125	205					1280	
CSMX50-10	10	60	70	50	30	212	1500	2460	 <p>M8 for charging/discharging per il caricamento/scaricamento 20 M8 x 12 (2x) for fixing per il fissaggio</p>
25	25	75	100					2460	
38	38	88	126					2510	
50	50	100	150					2590	
63	63	113	176					2590	
80	80	130	210					2590	
100	100	150	250					2650	
125	125	190	315					2670	
160	160	235	395					2680	
200	200	275	475					2690	
CSMX63-10	10	65	75	63	40 	159	2000	2900	 <p>M8 for charging/discharging per il caricamento/scaricamento 20 M8 x 12 (2x) for fixing per il fissaggio</p>
25	25	80	105					3270	
38	38	93	131					3430	
50	50	105	155					3490	
63	63	118	181					3500	
80	80	135	215					3500	
100	100	160	260					3580	
125	125	190	315					3580	
160	160	235	395					3690	
200	200	275	475					3750	
CSMX75-10	10	65	75	75	45	189	3000	4800	 <p>M8 for charging/discharging per il caricamento/scaricamento 40 M8 x 12 (4x) for fixing per il fissaggio</p>
25	25	80	105					5200	
38	38	93	131					5300	
50	50	105	155					5400	
63	63	118	181					5500	
80	80	135	215					5600	
100	100	155	255					5700	
125	125	200	325					5800	
160	160	250	410					5900	
200	200	300	500					6000	
CSMX95-25	25	90	115	95	58	189	5000	8500	 <p>M8 for charging/discharging per il caricamento/scaricamento 60 M8 x 12 (4x) for fixing per il fissaggio</p>
38	38	103	141					8700	
50	50	115	165					8800	
63	63	128	191					8900	
80	80	155	235					9000	
100	100	185	285					9100	
125	125	220	345					9200	
160	160	260	420					9300	
200	200	310	510					9400	
CSMX120-25	25	100	125					120	
38	38	113	151	15000					
50	50	125	175	15400					
63	63	138	201	15500					
80	80	160	240	15600					
100	100	190	290	15700					
125	125	225	350	15800					
160	160	270	430	17800					
200	200	320	520	18000					

• Available on request / Disponibili a richiesta

 Attention: see note on page 28 /  Attenzione: vedere nota a pag. 28

# Nano technology series

Nitrogen gas springs for press tools, dies and moulds / *Cilindri all'azoto per stampi*



## MICX

MICX series replaces the previous MIC series.  
 Diameter 25 mm, ready-to-use gas springs, charged at five different standard initial forces: 50 daN, 100 daN, 150 daN, 200 daN and 300 daN.  
**WHAT'S NEW:** upgraded with the new WIPERTECH and NANOTECH2 nano-technologies.  
**SELF-LUBRICATED** for millions of working cycles thanks to the nano-technologies (patent pending).  
**PROTECTED AGAINST CONTAMINANTS** with WIPERTECH protective wiper ring.  
**THE NEW MODELS WILL BE SUPPLIED ONLY WHEN THE OLD ONES ARE OUT OF STOCK.**

*Sostituisce la precedente serie MIC.*  
*Cilindri di diametro 25 mm già caricati e pronti per l'uso in cinque diverse forze iniziali standard: 50 daN, 100 daN, 150 daN, 200 daN e 300 daN.*  
**NOVITÀ:** aggiornata con le nuove nano-tecnologie WIPERTECH e NANOTECH2.  
**AUTOLUBRIFICATI** per milioni di cicli grazie alle nano-tecnologie (in corso di brevetto).  
**PROTETTI DA CONTAMINANTI** con anello raschiastelo di protezione WIPERTECH.  
**I NUOVI MODELLI SARANNO FORNITI SOLO AD ESAURIMENTO SCORTE DEI VECCHI.**

### MICX

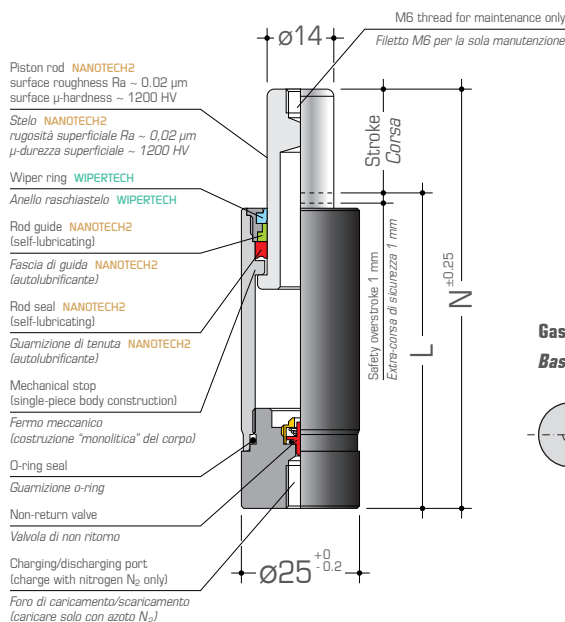

### Gas Spring base Base del cilindro

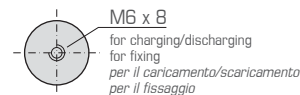

### Fixing possibilities

(see also our "Accessories for nitrogen gas springs for dies" catalogue)

### Fissaggi possibili

(vedi anche il nostro catalogo "Accessori per cilindri all'azoto per stampi")



### HOW TO ORDER

### ESEMPIO D'ORDINE

#### No. 8 pcs. MICX25-50-F150

No. 8 nitrogen gas springs series MICX, D = 25 mm, stroke length = 50 mm, initial force = 150 daN.

#### No. 8 MICX25-50-F150

N° 8 cilindri all'azoto serie MICX, D = 25 mm, corsa = 50 mm, forza iniziale = 150 daN.

### TECHNICAL NOTES

#### Important use instructions and maximum number of cycles per minute on pages 10-17.

For accessories and other mountings, see the "Accessories for nitrogen gas springs for dies" catalogue.

The MIC models are replaceable with the MICX models.

### NOTE TECNICHE

#### Importanti istruzioni d'uso e numero massimo di cicli/minuto alle pagine 10-17.

Per accessori e altri montaggi, consultare il catalogo "Accessori per cilindri all'azoto per stampi".  
 I modelli MIC sono sostituibili con i modelli MICX.

(\* Final force (force at full stroke) = Initial force × R

(\* Forza finale (forza a fine corsa) = Forza iniziale × R

MODEL MODELLO	MAX STROKE mm CORSA MAX mm	L mm	N mm	...F50 bar	...F50 daN	...F100 bar	...F100 daN	...F150 bar	...F150 daN	...F200 bar	...F200 daN	...F300 bar	...F300 daN	R (*)
MICX25-10- ...	10	50	60											1.5
15- ...	15	55	70											1.7
25- ...	25	65	90	32	50	65	100	97	150	130	200	195	300	1.7
38- ...	38	78	116											1.8
50- ...	50	90	140											1.9
80- ...	80	120	200											1.9

# Nano technology series

Nitrogen gas springs for press tools, dies and moulds / *Cilindri all'azoto per stampi*

WIPESTECH

NANOTECH2



PATENTS PENDING

## MCSM

New model!

Gas springs with low forces (available diameters: 19 mm and 25 mm).

WHAT'S NEW: new series in the catalogue, with the new WIPESTECH and NANOTECH2 nano-technologies.

SELF-LUBRICATED for millions of working cycles thanks to the nano-technologies (patent pending).

PROTECTED AGAINST CONTAMINANTS with WIPESTECH protective wiper ring.

*Cilindri con forze ridotte, disponibili nei diametri 19 mm e 25 mm.*

*NOVITÀ: nuova serie a catalogo, dotata delle nano-tecnologie WIPESTECH e NANOTECH2.*

*AUTOLUBRIFICATI per milioni di cicli grazie alle nano-tecnologie (in corso di brevetto).*

*PROTETTI DA CONTAMINANTI con anello raschiastelo di protezione WIPESTECH.*

### Fixing possibilities

(see also our "Accessories for nitrogen gas springs for dies" catalogue)

### Fissaggi possibili

(vedi anche il nostro catalogo "Accessori per cilindri all'azoto per stampi")



MCSM

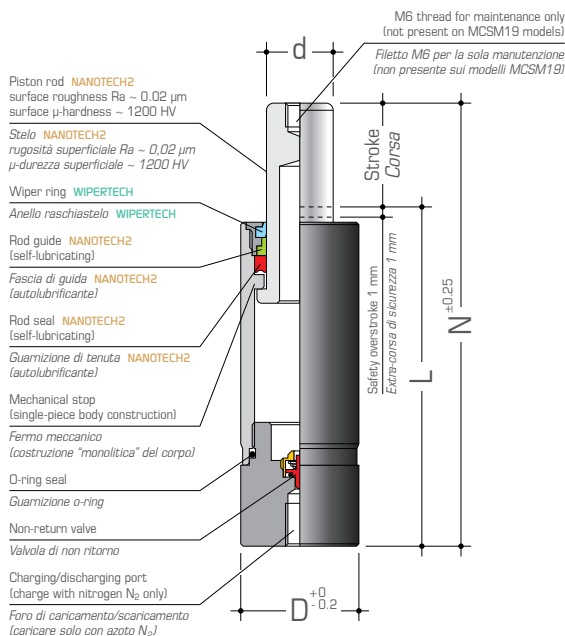

### TECHNICAL NOTES

#### Important use instructions and maximum number of cycles per minute on pages 10-17.

For accessories and other mountings, see the "Accessories for nitrogen gas springs for dies" catalogue.

### NOTE TECNICHE

#### Importanti istruzioni d'uso e numero massimo di cicli/minuto alle pagine 10-17.

Per accessori e altri montaggi, consultare il catalogo "Accessori per cilindri all'azoto per stampi".

MODEL MODELLO	MAX STROKE mm CORSIA MAX mm	L mm	N mm	D mm	d mm	bar	daN	daN	GAS SPRING BASE BASE DEL CILINDRO
MCSM19-10	10	55	65	19	10	102	80	105	<p>M6 x 12 for charging/discharging for fixing per il caricamento/scaricamento per il fissaggio</p>
15	15	60	75					110	
25	25	70	95					115	
38	38	83	121					120	
50	50	95	145					130	
80	80	125	205					140	
MCSM25-10	10	55	65	25	14	104	160	230	<p>M6 x 8 for charging/discharging for fixing per il caricamento/scaricamento per il fissaggio</p>
15	15	60	75					240	
25	25	70	95					260	
38	38	83	121					280	
50	50	95	145					290	
80	80	125	205					300	

# Standard series

Nitrogen gas springs for press tools, dies and moulds / Cilindri all'azoto per stampi



## TOP

Gas springs with bore seal design. The TOP25 models are still the most powerful gas springs with diameter 25 mm, generating an initial force of 400 daN (when possible, the use of MSML25 models is recommended, since they feature a more advanced technology and generate an initial force of 360 daN). TOP series gas springs must be manually lubricated, as they are not self-lubricated. TOP series gas springs must be protected against contaminants, as they cannot be provided with a wiper ring. RECOMMENDED only for diameter 25 mm, in case the initial force of 360 daN generated by the MSML25 models is not enough for the specific application. For the other diameters, the use of CSX models is recommended because of the more advanced technology.

Cilindri con tenuta di tipo pistone (tenuta della guarnizione sulle pareti interne del corpo del cilindro). Rimangono i cilindri più potenti per quanto riguarda il diametro 25 mm, che sviluppa una forza iniziale di 400 daN (si valuti comunque la possibilità di utilizzare i modelli MSML25, che a parità di diametro sviluppano una forza iniziale di 360 daN e sono dotati di una tecnologia più avanzata). I cilindri della serie TOP devono essere lubrificati manualmente, non essendo autolubrificati. I cilindri della serie TOP devono essere protetti da contaminanti, non potendo essere dotati di anello raschiastelo. CONSIGLIATI per il solo diametro 25 mm qualora la forza iniziale di 360 daN sviluppata dai modelli MSML25 non sia sufficiente per l'applicazione. Per gli altri diametri, si consiglia l'utilizzo dei modelli CSX data la tecnologia più avanzata.

### Fixing possibilities

(see also our "Accessories for nitrogen gas springs for dies" catalogue)

### Fissaggi possibili

(vedi anche il nostro catalogo "Accessori per cilindri all'azoto per stampi")

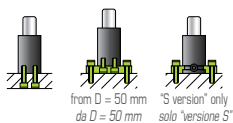

### TOP 25/120

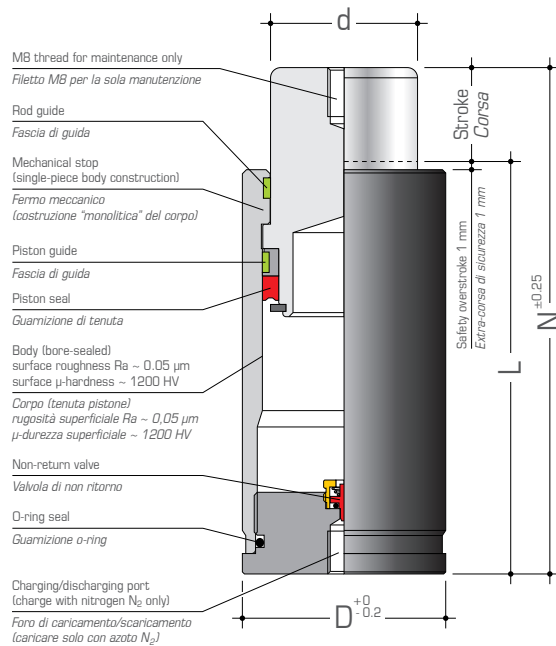

### TECHNICAL NOTES

#### Important use instructions and maximum number of cycles per minute on pages 10-17.

For accessories and other mountings, see the "Accessories for nitrogen gas springs for dies" catalogue.

### NOTE TECNICHE

#### Importanti istruzioni d'uso e numero massimo di cicli/minuto alle pagine 10-17.

Per accessori e altri montaggi, consultare il catalogo "Accessori per cilindri all'azoto per stampi".

### "S" VERSION

With fixing groove and G1/8 side port, linkable to open system, from D = 50 mm.

- » **L and N dimensions: + 20 mm**
- » Add an **-S** to order them
- Example: no. 8 pcs. TOP50-50-**S**

### VERSIONE "S"

Da D = 50 mm, scanalatura di fissaggio e foro laterale G1/8, per collegamento a sistema.

- » **Quote L e N: + 20 mm**
- » Per ordinarli, aggiungere una **-S**
- Esempio: n° 8 TOP50-50-**S**

### "S" version

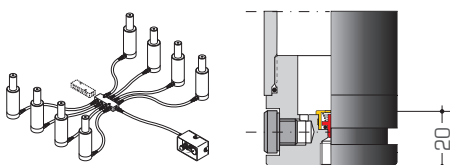



MODEL MODELLO	MAX STROKE mm CORSA MAX mm	L mm	N mm	D mm	d mm	bar	daN	daN	GAS SPRING BASE BASE DEL CILINDRO
TOP25-10	10	65	75	25	16	157	400	770	<p>M4 for charging/discharging per il caricamento/scaricamento</p> <p>M5 x 7 (2x) for fixing per il fissaggio</p>
15	15	75	90					790	
25	25	95	120					800	
50	50	145	195					810	
TOP32-10	10	65	75	32	20	154	700	1500	<p>M4 for charging/discharging per il caricamento/scaricamento</p> <p>M6 x 8 (2x) for fixing per il fissaggio</p>
15	15	75	90					1520	
25	25	95	120					1530	
50	50	145	195					1540	
TOP38-10	10	65	75	38	24	162	1000	1870	<p>M8 for charging/discharging per il caricamento/scaricamento</p> <p>M6 x 10 (2x) for fixing per il fissaggio</p>
15	15	75	90					1880	
25	25	95	120					1930	
50	50	145	195					2000	
TOP50-10	10	70	80	50	36	159	2000	3750	<p>M8 for charging/discharging per il caricamento/scaricamento</p> <p>M8 x 12 (2x) for fixing per il fissaggio</p>
15	15	80	95					3850	
25	25	100	125					3900	
50	50	150	200					3950	
TOP63-10	10	75	85	63	46	153	3000	5300	<p>M8 for charging/discharging per il caricamento/scaricamento</p> <p>M8 x 12 (2x) for fixing per il fissaggio</p>
15	15	85	100					5650	
25	25	105	130					5690	
50	50	155	205					5790	
TOP75-10	10	75	85	75	56	142	4000	6900	<p>M8 for charging/discharging per il caricamento/scaricamento</p> <p>M8 x 12 (4x) for fixing per il fissaggio</p>
15	15	85	100					7100	
25	25	105	130					7100	
50	50	155	205					7300	
TOP95-10	10	80	90	95	70	154	7000	10800	<p>M8 for charging/discharging per il caricamento/scaricamento</p> <p>M8 x 14 (4x) for fixing per il fissaggio</p>
15	15	90	105					11700	
25	25	110	135					11800	
50	50	160	210					11900	
TOP120-10	10	90	100	120	90	141	10000	15000	<p>M8 for charging/discharging per il caricamento/scaricamento</p> <p>M10 x 16 (4x) for fixing per il fissaggio</p>
15	15	100	115					16000	
25	25	120	145					17000	
50	50	170	220					18000	

# Standard series

Nitrogen gas springs for press tools, dies and moulds / *Cilindri all'azoto per stampi*



## TOP

Threaded-body, compact gas springs with bore seal design. TOP series gas springs must be manually lubricated, as they are not self-lubricated. TOP series gas springs must be protected against contaminants, as they cannot be provided with a wiper ring.

*Cilindri con corpo filettato di dimensioni ridotte, con tenuta di tipo pistone (tenuta della guarnizione sulle pareti interne del corpo del cilindro).*

*I cilindri della serie TOP devono essere lubrificati manualmente, non essendo autolubrificati.*

*I cilindri della serie TOP devono essere protetti da contaminanti, non potendo essere dotati di anello raschiastelo.*

### Fixing possibilities

(see also our "Accessories for nitrogen gas springs for dies" catalogue)

### Fissaggi possibili

(vedi anche il nostro catalogo "Accessori per cilindri all'azoto per stampi")



### TOP 12/20

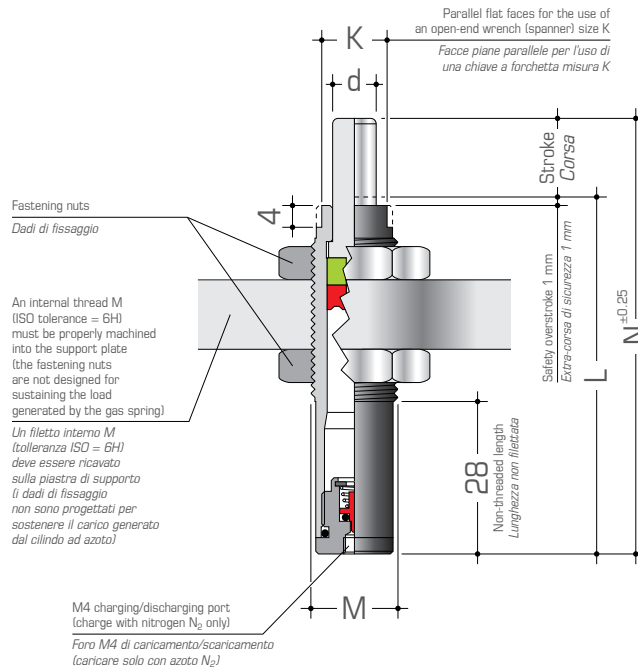

### TECHNICAL NOTES

### NOTE TECNICHE

**Important use instructions and maximum number of cycles per minute on pages 10-17.**

**Importanti istruzioni d'uso e numero massimo di cicli/minuto alle pagine 10-17.**

MODEL MODELLO	MAX STROKE mm CORSIA MAX mm	L mm	N mm	M	d mm	K mm	bar	daN	daN
TOP12-10	10	55	65	M12 x 1.25	5	9	150	50	80
15	15	65	80						90
TOP14-10	10	55	65	M14 x 1.5	6	11	150	75	130
15	15	65	80						140
TOP16-10	10	55	65	M16 x 1.5	8	13	127	100	170
15	15	65	80						180
TOP20-10	10	55	65	M20 x 1.5	10	17	151	200	420
15	15	65	80						430

### Fastening nuts / Dadi di fissaggio

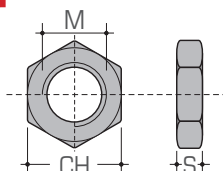

MODEL MODELLO	M	S mm	CH mm
TOP-D-12	M12 x 1.25	7	19
14	M14 x 1.5	8	22
16	M16 x 1.5	8	24
20	M20 x 1.5	9	30

# VDI 3003 standard series

Nitrogen gas springs for press tools, dies and moulds / Cilindri all'azoto per stampi



## CVDI

The CVDI nitrogen gas springs are in accordance with the VDI 3003 standard.

I cilindri della serie CVDI sono conformi alla norma VDI 3003.

### CVDI 19/25

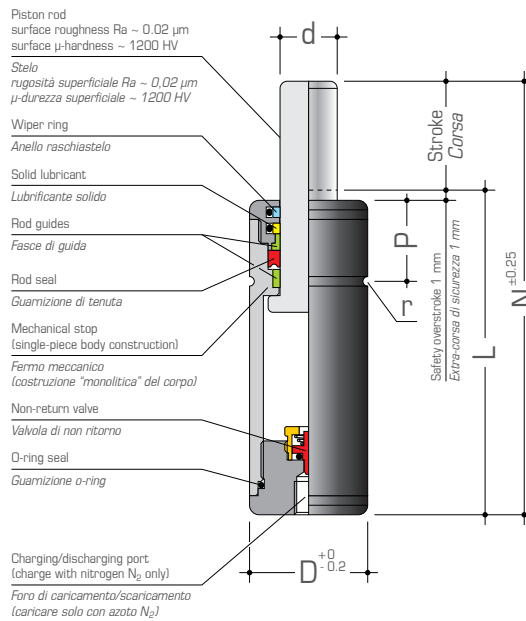

#### Fixing possibilities

(see also our "Accessories for nitrogen gas springs for dies" catalogue)

#### Fissaggi possibili

(vedi anche il nostro catalogo "Accessori per cilindri all'azoto per stampi")

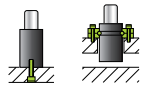

#### TECHNICAL NOTES

##### Important use instructions and maximum number of cycles per minute on pages 10-17.

For accessories and other mountings, see the "Accessories for nitrogen gas springs for dies" catalogue.

#### NOTE TECNICHE

##### Importanti istruzioni d'uso e numero massimo di cicli/minuto alle pagine 10-17.

Per accessori e altri montaggi, consultare il catalogo "Accessori per cilindri all'azoto per stampi".

MODEL MODELLO	MAX STROKE mm CORSA MAX mm	L mm	N mm	D mm	d mm	P mm	r mm				GAS SPRING BASE BASE DEL CILINDRO
								bar	daN	daN	
CVDI19-15	15	57	72	19	8	17	1	180	90	120	 M6 x 7 for charging/discharging for fixing per il caricamento/scaricamento per il fissaggio
25	25	67	92							125	
38	38	80	118							125	
50	50	92	142							130	
63	63	108	171							130	
80	80	125	205							130	
CVDI25-15	15	57	72	25	12	17	1	177	200	320	 M6 x 7 for charging/discharging for fixing per il caricamento/scaricamento per il fissaggio
25	25	67	92							330	
38	38	80	118							335	
50	50	92	142							335	
63	63	108	171							335	
80	80	125	205							340	
100	100	145	245							340	
125	125	170	295							340	

# Standard series

Nitrogen gas springs for press tools, dies and moulds / Cilindri all'azoto per stampi



## CISO 19/25

The CISO series gas springs are in accordance with the ISO 11901:1995 standard, which starts from  $\varnothing$  32 mm. This CISO series includes the  $\varnothing$  19 mm and  $\varnothing$  25 mm also. Flanges are in accordance with the ISO standard too, and can be found in the "Accessories for nitrogen gas springs for dies" catalogue.

I cilindri della serie CISO sono conformi alla norma ISO 11901:1995, che inizia dal  $\varnothing$  32 mm. Questa serie CISO fornisce anche i  $\varnothing$  19 mm e  $\varnothing$  25 mm. Anche le flange di fissaggio sono realizzate in totale conformità alla norma ISO, e possono essere trovate nel catalogo "Accessori per cilindri all'azoto per stampi".

### CISO 19 / 25

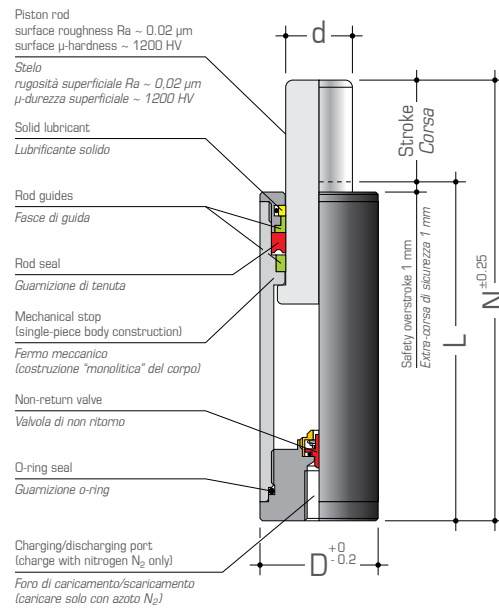

### Fixing possibilities

(see also our "Accessories for nitrogen gas springs for dies" catalogue)

### Fissaggi possibili

(vedi anche il nostro catalogo "Accessori per cilindri all'azoto per stampi")



### TECHNICAL NOTES





#### Important use instructions and maximum number of cycles per minute on pages 10-17.

For accessories and other mountings, see the "Accessories for nitrogen gas springs for dies" catalogue.

### NOTE TECNICHE

#### Importanti istruzioni d'uso e numero massimo di cicli/minuto alle pagine 10-17.

Per accessori e altri montaggi, consultare il catalogo "Accessori per cilindri all'azoto per stampi".

MODEL MODELLO	MAX STROKE mm CORSA MAX mm	L mm	N mm	D mm	d mm	 bar	 daN	 daN	GAS SPRING BASE BASE DEL CILINDRO
CISO19-10	• 10	55	65	19	10	128	100	135	 M6 x 8 for charging/discharging for fixing per il caricamento/scaricamento per il fissaggio
16	• 16	61	77					140	
25	• 25	70	95					150	
38	• 38	83	121					170	
50	• 50	95	145					170	
63	• 63	108	171					180	
80	• 80	125	205					185	
CISO25-10	• 10	55	65	25	14	129	200	300	 M6 x 10 for charging/discharging for fixing per il caricamento/scaricamento per il fissaggio
16	• 16	61	77					330	
25	• 25	70	95					360	
38	• 38	83	121					410	
50	• 50	95	145					420	
63	• 63	108	171					440	
80	• 80	125	205					440	

• Without scraper ring / Senza raschiastelo

# ISO 11901-1 standard series

Nitrogen gas springs for press tools, dies and moulds / Cilindri all'azoto per stampi



## CISO 32/38

CISO 32 / 38

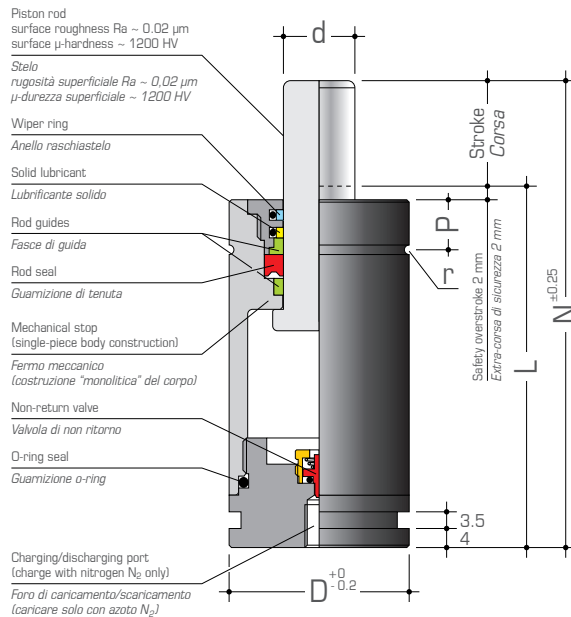

### Fixing possibilities

(see also our "Accessories for nitrogen gas springs for dies" catalogue)

### Fissaggi possibili

(vedi anche il nostro catalogo "Accessori per cilindri all'azoto per stampi")

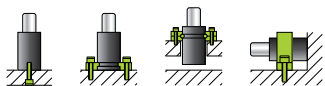

### TECHNICAL NOTES





#### Important use instructions and maximum number of cycles per minute on pages 10-17.

For accessories and other mountings, see the "Accessories for nitrogen gas springs for dies" catalogue.

### NOTE TECNICHE

#### Importanti istruzioni d'uso e numero massimo di cicli/minuto alle pagine 10-17.

Per accessori e altri montaggi, consultare il catalogo "Accessori per cilindri all'azoto per stampi".

MODEL MODELLO	MAX STROKE mm CORSA MAX mm	L mm	N mm	D mm	d mm	P mm	r mm				GAS SPRING BASE BASE DEL CILINDRO
								bar	daN	daN	
CISO32-10	10	60	70							185	 <p>M6 x 9 for charging/discharging for fixing per il caricamento/scaricamento per il fissaggio</p>
16	16	66	82							190	
25	25	75	100	32	11.5	10.5	1	145	150	190	
50	50	100	150							195	
80	80	130	210							195	
CISO38-10	10	60	70							320	 <p>M6 x 9 for charging/discharging for fixing per il caricamento/scaricamento per il fissaggio</p>
13	13	63	76							320	
16	16	66	82							320	
25	25	75	100							330	
38	38	88	126	38	15	10.5	1	142	250	330	
50	50	100	150							340	
63	63	113	176							345	
75	75	126	201							345	
80	80	130	210							350	

# ISO 11901-1 standard series

Nitrogen gas springs for press tools, dies and moulds / Cilindri all'azoto per stampi



## CISO 45/150

CISO 45 / 150

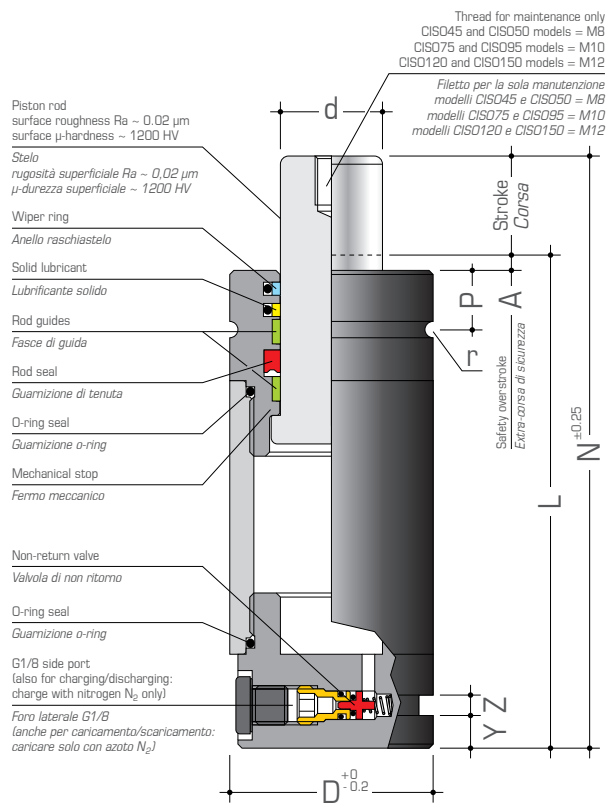

### Fixing possibilities

(see also our "Accessories for nitrogen gas springs for dies" catalogue)

### Fissaggi possibili

(vedi anche il nostro catalogo "Accessori per cilindri all'azoto per stampi")

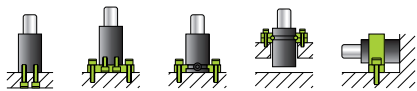

### TECHNICAL NOTES

**Important use instructions and maximum number of cycles per minute on pages 10-17.**

For accessories and other mountings, see the "Accessories for nitrogen gas springs for dies" catalogue.

### NOTE TECNICHE

**Importanti istruzioni d'uso e numero massimo di cicli/minuto alle pagine 10-17.**

Per accessori e altri montaggi, consultare il catalogo "Accessori per cilindri all'azoto per stampi".

### Linkable / Collegabili

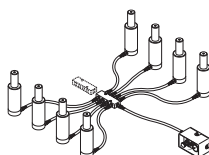





Ready with fixing groove and G1/8 side port, linkable to open system, from D = 45 mm.

**ATTENTION: make sure to fully discharge the gas spring before connecting it to open system (see the instructions supplied together with the charging and discharging set COMPL).**

Pronti, da D = 45 mm, con scanalatura di fissaggio e foro laterale G1/8, per collegamento a sistema.

**ATTENZIONE: assicurarsi di scaricare completamente il cilindro prima di collegarlo a sistema (vedi le istruzioni fornite assieme al set di carico e scarico COMPL).**

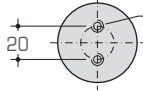
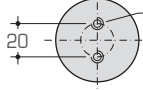
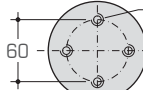

MODEL MODELLO	MAX STROKE mm CORSA MAX mm	L mm	N mm	D mm	d mm	P mm	A mm	r mm	Z mm	Y mm	 bar	 daN	 daN	GAS SPRING BASE BASE DEL CILINDRO
CISO45-25	25	110	135	45	20	14.5	2	1	3.5	4	159	500	650	 M8 x 13 (2x) for fixing per il fissaggio
50	50	135	185										680	
80	80	165	245										720	
CISO50-13	13	107	120	50	25	14.5	3	2	5	8	153	750	1090	 M8 x 13 (2x) for fixing per il fissaggio
25	25	120	145										1100	
38	38	133	171										1110	
50	50	145	195										1150	
63	63	159	222										1190	
75	75	170	245										1200	
80	80	175	255										1210	
100	100	195	295										1220	
125 •	125	220	345										1230	
160 •	160	255	415										1240	
CISO75-13	13	121	134										75	
25	25	135	160	2070										
38	38	147	185	2100										
50	50	160	210	2150										
63	63	173	236	2200										
75	75	184	259	2220										
80	80	190	270	2250										
100	100	210	310	2280										
125 •	125	235	360	2340										
160 •	160	270	430	2390										
CISO95-13	13	131	144	95	50	21	3	2.5	5	8	153	3000	4200	 M8 x 13 (4x) for fixing per il fissaggio
25	25	145	170										4250	
38	38	157	195										4300	
50	50	170	220										4350	
63	63	183	246										4400	
75	75	194	269										4500	
80	80	200	280										4700	
100	100	220	320										4700	
125 •	125	245	370										4700	
160 •	160	280	440	4700										
CISO120-13	13	151	164	120	65	22.5	3	2.5	5	8	151	5000	6300	 M10 x 16 (4x) for fixing per il fissaggio
25	25	165	190										6400	
38	38	177	215										6600	
50	50	190	240										7000	
63	63	203	266										7300	
75	75	214	289										7400	
80	80	220	300										7500	
100	100	240	340										7600	
125 •	125	265	390										7700	
160 •	160	300	460										7800	
CISO150-13	13	168	181	150	80	24.5	3	2.5	5	8	150	7500	10100	 M10 x 16 (4x) for fixing per il fissaggio
25	25	180	205										10300	
38	38	193	231										10500	
50	50	205	255										10700	
63	63	219	282										10900	
75	75	230	305										11100	
80	80	235	315										11300	
100	100	255	355										11500	
125 •	125	280	405										11700	
160 •	160	315	475	12000										

• Available on request / Disponibili a richiesta

# Standard series

Nitrogen gas springs for press tools, dies and moulds / Cilindri all'azoto per stampi



**Replaced by CSMF series (check technical specifications).  
If the side port for linking to open system is needed,  
see CSMF series - "S version" (check technical specifications).**

**Sostituita dalla serie CSMF (controllare le specifiche tecniche).  
Se vi è la necessità di avere il foro laterale per collegamento a sistema,  
si veda la serie CSMF - "versione S" (controllare le specifiche tecniche).**

## CF

Nitrogen gas springs with fixing flange, threaded on the cylinder body to ensure a higher safety level compared with flanges fixed with lock ring. With increased initial force, linkable to open system.

Cilindri con flangia di fissaggio, filettata sul corpo per una maggiore sicurezza rispetto alle flange fissate con anelli metallici. Potenziati nelle forze, collegabili a sistema.

### Fixing possibilities

(see also our "Accessories for nitrogen gas springs for dies" catalogue)

### Fissaggi possibili

(vedi anche il nostro catalogo "Accessori per cilindri all'azoto per stampi")



### CF

Piston rod  
surface roughness Ra ~ 0.02 µm  
surface µ-hardness ~ 1200 HV  
Stelo  
rugosità superficiale Ra ~ 0.02 µm  
µ-durezza superficiale ~ 1200 HV

Wiper ring  
Anello raschiastelo

Solid lubricant  
Lubrificante solido

Built-on flange with dedicated fixing holes  
Flangia incorporata con relativi fori di fissaggio

Rod guides  
Fasce di guida

Rod seal  
Guarnizione di tenuta

Mechanical stop (single-piece body construction)  
Fermo meccanico (costruzione "monolitica" del corpo)

O-ring seal  
Guarnizione o-ring

Non-return valve  
Valvola di non ritorno

G1/8 side port  
Foro laterale G1/8

MB charging/discharging port (charge with nitrogen N<sub>2</sub> only)  
Foro MB di caricamento/scaricamento (caricare solo con azoto N<sub>2</sub>)

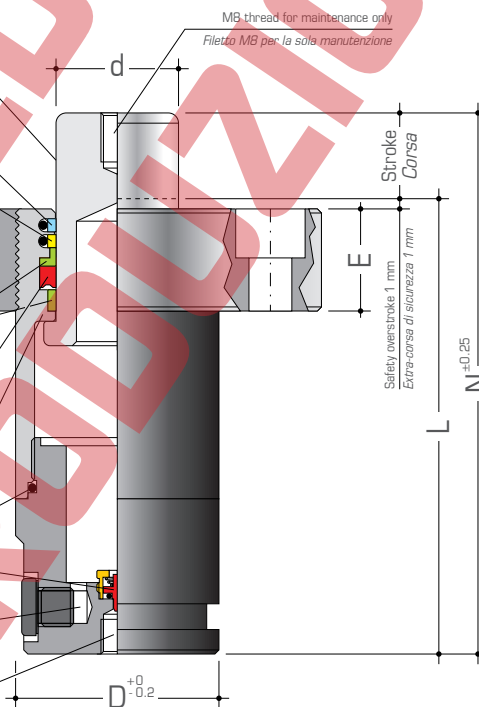

### HOW TO ORDER

### ESEMPIO D'ORDINE

No. 8 pcs. CF50-80 1500daN

No. 8 CF50-80 1500daN

No. 8 nitrogen gas springs series CF with built-on flange, D = 50 mm, stroke length = 80 mm, initial force = 1500 daN.

N° 8 cilindri all'azoto serie CF con flangia incorporata, D = 50 mm, corsa = 80 mm, forza iniziale = 1500 daN.

**ATTENTION: specify the required initial force.**

**ATTENZIONE: specificare la forza iniziale desiderata.**

### TECHNICAL NOTES

**Important use instructions and maximum number of cycles per minute on pages 10-17.**

For accessories, see the "Accessories for nitrogen gas springs for dies" catalogue.

### NOTE TECNICHE

**Importanti istruzioni d'uso e numero massimo di cicli/minuto alle pagine 10-17.**

Per accessori, consultare il catalogo "Accessori per cilindri all'azoto per stampi".

### Linkable / Collegabili

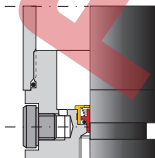
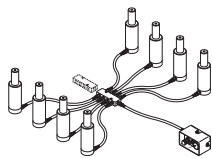



Ready with G1/8 side port, linkable to open system.

**ATTENTION: make sure to fully discharge the gas spring before connecting it to open system (see the instructions supplied together with the charging and discharging set COMPL).**

Pronti con foro laterale G1/8, per collegamento a sistema.

**ATTENZIONE: assicurarsi di scaricare completamente il cilindro prima di collegarlo a sistema (vedi le istruzioni fornite assieme al set di carico e scarico COMPL).**

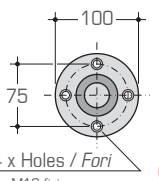
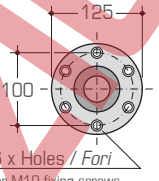
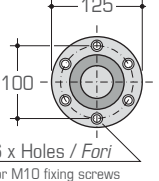
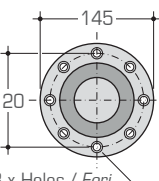
MODEL MODELLO	MAX STROKE mm CORSA MAX mm	L mm	N mm	D mm	d mm	E mm	 bar	 daN	 daN	FLANGES FLANGE
CF50-10	10	95	105	50	30	25	212	1500	2400	 4 x Holes / Fori for M10 fixing screws per viti M10 di fissaggio
25	25	110	135							
38	38	123	161							
50	50	135	185							
63	63	148	211							
80	80	165	245							
100	100	195	295							
125	125	220	345							
160	160	255	415							
200	200	295	495							
CF63-10	10	95	105	63	36	25	196	2000	3200	 6 x Holes / Fori for M10 fixing screws per viti M10 di fissaggio
25	25	110	135							
38	38	123	161							
50	50	135	185							
63	63	148	211							
80	80	165	245							
100	100	185	285							
125	125	220	345							
160	160	255	415							
200	200	295	495							
CF75-10	10	105	115	75	45	25	189	3000	4800	 6 x Holes / Fori for M10 fixing screws per viti M10 di fissaggio
25	25	120	145							
38	38	133	171							
50	50	145	195							
63	63	158	221							
80	80	175	255							
100	100	200	300							
125	125	225	350							
160	160	265	425							
200	200	310	510							
CF95-25	25	130	155	95	58	25	189	5000	8000	 8 x Holes / Fori for M10 fixing screws per viti M10 di fissaggio
38	38	143	181							
50	50	155	205							
63	63	168	231							
80	80	190	270							
100	100	210	310							
125	125	245	370							
160	160	280	440							
200	200	330	530							
CF120-25	25	140	165							
38	38	153	191							
50	50	165	215							
63	63	178	241							
80	80	195	275							
100	100	215	315							
125	125	250	375							
160	160	290	450							
200	200	340	540							

# Standard series

Nitrogen gas springs for press tools, dies and moulds / Cilindri all'azoto per stampi



## CSMF

Compact nitrogen gas springs with fixing flange, threaded on the cylinder body to ensure a higher safety level compared with flanges fixed with lock ring.

WHAT'S NEW: upgraded with the new WIPERTECH nano-technology.

THE NEW MODELS WILL BE SUPPLIED ONLY WHEN THE OLD ONES ARE OUT OF STOCK.

Cilindri compatti con flangia di fissaggio, filettata sul corpo per una maggiore sicurezza rispetto alle flange fissate con anelli metallici.

NOVITÀ: aggiornata con la nuova nano-tecnologia WIPERTECH.

I NUOVI MODELLI SARANNO FORNITI SOLO AD ESAURIMENTO SCORTE DEI VECCHI.

### CSMF

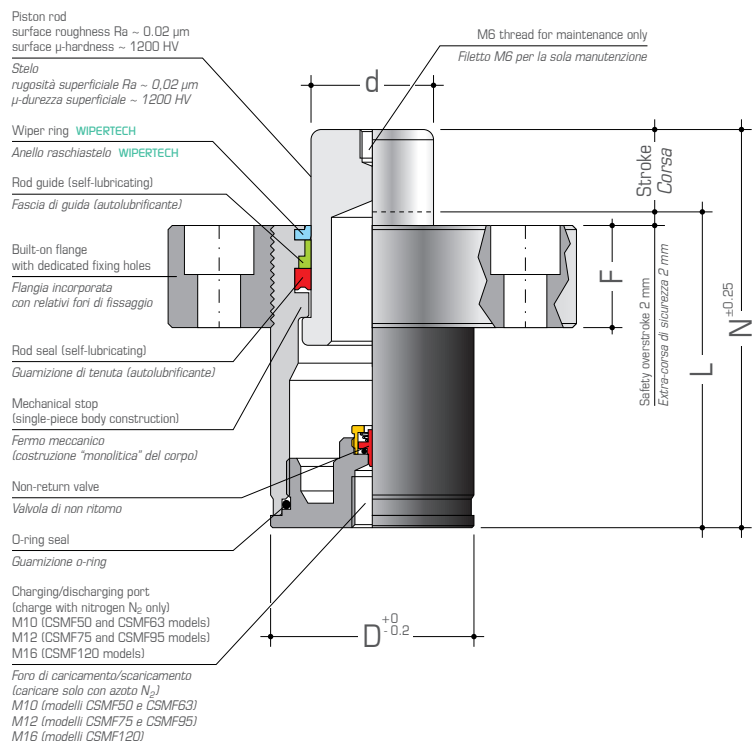

### Fixing possibilities

(see also our "Accessories for nitrogen gas springs for dies" catalogue)

### Fissaggi possibili

(vedi anche il nostro catalogo "Accessori per cilindri all'azoto per stampi")



### HOW TO ORDER

#### No. 8 pcs. CSMF50-80 1500daN

No. 8 nitrogen gas springs series CSMF with built-on flange, D = 50 mm, stroke length = 80 mm, initial force = 1500 daN.

**ATTENTION: specify the required initial force.**

### ESEMPIO D'ORDINE

#### No. 8 CSMF50-80 1500daN

N° 8 cilindri all'azoto serie CSMF con flangia incorporata, D = 50 mm, corsa = 80 mm, forza iniziale = 1500 daN.

**ATTENZIONE: specificare la forza iniziale desiderata.**

### TECHNICAL NOTES

#### Important use instructions and maximum number of cycles per minute on pages 10-17.

For accessories, see the "Accessories for nitrogen gas springs for dies" catalogue.

#### ⚠ ATTENTION:

**Rod diameter d = 40 mm for the CSMF63 models (previous version: d = 36 mm).**

### NOTE TECNICHE

#### Importanti istruzioni d'uso e numero massimo di cicli/minuto alle pagine 10-17.

Per accessori, consultare il catalogo "Accessori per cilindri all'azoto per stampi".

#### ⚠ ATTENZIONE:

**Diametro dello stelo d = 40 mm per i modelli CSMF63 (versione precedente: d = 36 mm).**

### "S" version

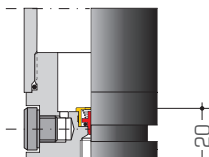
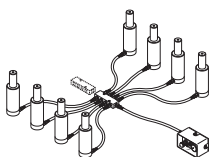

### "S" VERSION

With G1/8 side port, linkable to open system.

» L and N dimensions: + 20 mm

» Add an -S to order them

Example: no. 8 pcs. CSMF50-80-S





### VERSIONE "S"

Con foro laterale G1/8, per collegamento a sistema.

» Quote L e N: + 20 mm

» Per ordinarli, aggiungere una -S

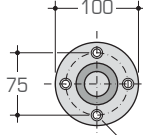
Esempio: n° 8 CSMF50-80-S

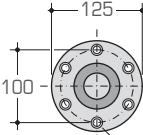
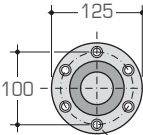
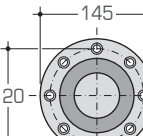
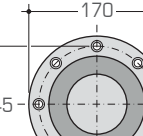
MODEL MODELLO	MAX STROKE mm CORSA MAX mm	L mm	N mm	D mm	d mm	F mm	 bar	 daN	 daN	FLANGES FLANGE
CSMF50-10	10	60	70	50	30	24	212	1500	2460	 4 x Holes / Fori for M10 fixing screws per viti M10 di fissaggio
25	25	75	100						2460	
38	38	88	126						2510	
50	50	100	150						2590	
63	63	113	176						2590	
80	80	130	210						2590	
100	100	150	250						2650	
125	125	190	315						2670	
160	160	235	395						2680	
200	200	275	475						2690	
CSMF63-10	10	65	75	63	40 	24	159	2000	2900	 6 x Holes / Fori for M10 fixing screws per viti M10 di fissaggio
25	25	80	105						3270	
38	38	93	131						3430	
50	50	105	155						3490	
63	63	118	181						3500	
80	80	135	215						3500	
100	100	160	260						3580	
125	125	190	315						3580	
160	160	235	395						3690	
200	200	275	475						3750	
CSMF75-10	10	65	75	75	45	24	189	3000	4800	 6 x Holes / Fori for M10 fixing screws per viti M10 di fissaggio
25	25	80	105						5200	
38	38	93	131						5300	
50	50	105	155						5400	
63	63	118	181						5500	
80	80	135	215						5600	
100	100	155	255						5700	
125	125	200	325						5800	
160	160	250	410						5900	
200	200	300	500						6000	
CSMF95-25	25	90	115	95	58	24	189	5000	8500	 8 x Holes / Fori for M10 fixing screws per viti M10 di fissaggio
38	38	103	141						8700	
50	50	115	165						8800	
63	63	128	191						8900	
80	80	155	235						9000	
100	100	185	285						9100	
125	125	220	345						9200	
160	160	260	420						9300	
200	200	310	510						9400	
CSMF120-25	25	100	125	120	75	34	204	9000	14000	 8 x Holes / Fori for M10 fixing screws per viti M10 di fissaggio
38	38	113	151						15000	
50	50	125	175						15400	
63	63	138	201						15500	
80	80	160	240						15600	
100	100	190	290						15700	
125	125	225	350						15800	
160	160	270	430						17800	
200	200	320	520	18000						

• Available on request / Disponibili a richiesta

 Attention: see note on page 42 /  Attenzione: vedere nota a pag. 42

Nitrogen gas springs for press tools, dies and moulds / Cilindri all'azoto per stampi

# Standard series

Nitrogen gas springs for press tools, dies and moulds / Cilindri all'azoto per stampi



Replaced by CSMT series (check technical specifications).  
Sostituita dalla serie CSMT (controllare le specifiche tecniche).

## CT

The CT series nitrogen gas springs have the threaded body to allow a different fixing.

I cilindri della serie CT hanno il corpo filettato che permette un fissaggio alternativo.

### Fixing possibilities

(see also our "Accessories for nitrogen gas springs for dies" catalogue)

### Fissaggi possibili

(vedi anche il nostro catalogo "Accessori per cilindri all'azoto per stampi")



### CT38

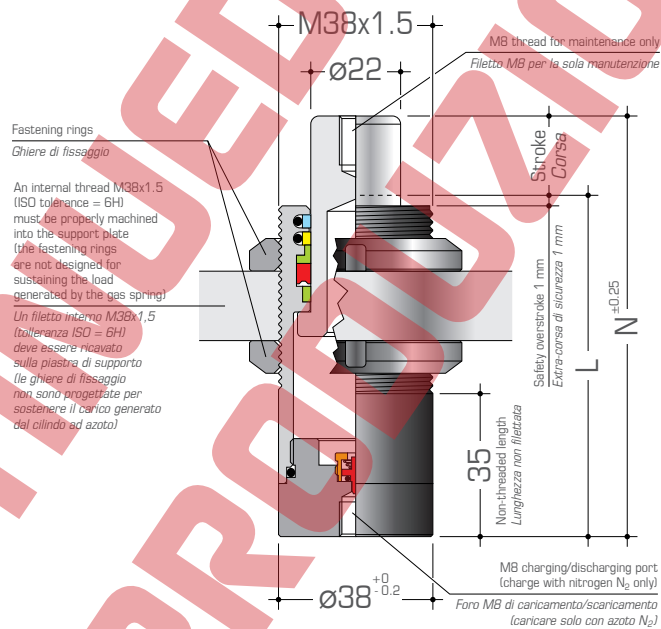

### HOW TO ORDER

### ESEMPIO D'ORDINE

#### No. 8 pcs. CT38-50 750daN

No. 8 nitrogen gas springs series CT with threaded body, D = 38 mm, stroke length = 50 mm, initial force = 750 daN.

**ATTENTION: specify the required initial force.**

#### No. 8 CT38-50 750daN

N° 8 cilindri all'azoto serie CT con corpo filettato, D = 38 mm, corsa = 50 mm, forza iniziale = 750 daN.

**ATTENZIONE: specificare la forza iniziale desiderata.**

### TECHNICAL NOTES

**Important use instructions and maximum number of cycles per minute on pages 10-17.**

For accessories, see the "Accessories for nitrogen gas springs for dies" catalogue.

**ATTENTION:** the CT38 models correspond to the old C38...S models.

### NOTE TECNICHE

**Importanti istruzioni d'uso e numero massimo di cicli/minuto alle pagine 10-17.**

Per accessori, consultare il catalogo "Accessori per cilindri all'azoto per stampi".

**ATTENZIONE:** i modelli CT38 corrispondono ai vecchi modelli C38...S

- Available on request / Disponibili a richiesta
- Two fastening rings are supplied with each gas spring / Con ogni cilindro sono fornite due ghiera di fissaggio

MODEL MODELLO	MAX STROKE mm CORSIA MAX mm	L mm	N mm	bar	daN	daN
CT38-10	10	65	75	197	750	1200
15	15	70	85			
25	25	80	105			
38	38	93	131			
50	50	105	155			
80	80	140	220			



# Standard series

Nitrogen gas springs for press tools, dies and moulds / *Cilindri all'azoto per stampi*



PATENTS PENDING

## CSMT

The CSMT series compact nitrogen gas springs have the threaded body to allow a different fixing.

WHAT'S NEW: upgraded with the new WIPERTECH nano-technology.

THE NEW MODELS WILL BE SUPPLIED ONLY WHEN THE OLD ONES ARE OUT OF STOCK.

I cilindri compatti della serie CSMT hanno il corpo filettato che permette un fissaggio alternativo.

NOVITÀ: aggiornata con la nuova nano-tecnologia WIPERTECH.

I NUOVI MODELLI SARANNO FORNITI SOLO AD ESAURIMENTO SCORTE DEI VECCHI.

### TECHNICAL NOTES

#### Important use instructions and maximum number of cycles per minute on pages 10-17.

For accessories, see the "Accessories for nitrogen gas springs for dies" catalogue.

### NOTE TECNICHE

#### Importanti istruzioni d'uso e numero massimo di cicli/minuto alle pagine 10-17.

Per accessori, consultare il catalogo "Accessori per cilindri all'azoto per stampi".

### HOW TO ORDER

#### No. 8 pcs. CSMT38-50 750daN

No. 8 nitrogen gas springs series CSMT with threaded body, D = 38 mm, stroke length = 50 mm, initial force = 750 daN.

**ATTENTION: specify the required initial force.**

### ESEMPIO D'ORDINE

#### No. 8 CSMT38-50 750daN

N° 8 cilindri all'azoto serie CSMT con corpo filettato, D = 38 mm, corsa = 50 mm, forza iniziale = 750 daN.

**ATTENZIONE: specificare la forza iniziale desiderata.**

### Fixing possibilities

(see also our "Accessories for nitrogen gas springs for dies" catalogue)

### Fissaggi possibili

(vedi anche il nostro catalogo "Accessori per cilindri all'azoto per stampi")



CSMT 38

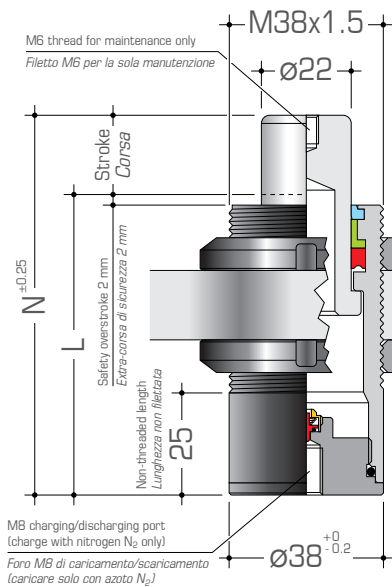

CSMT 50

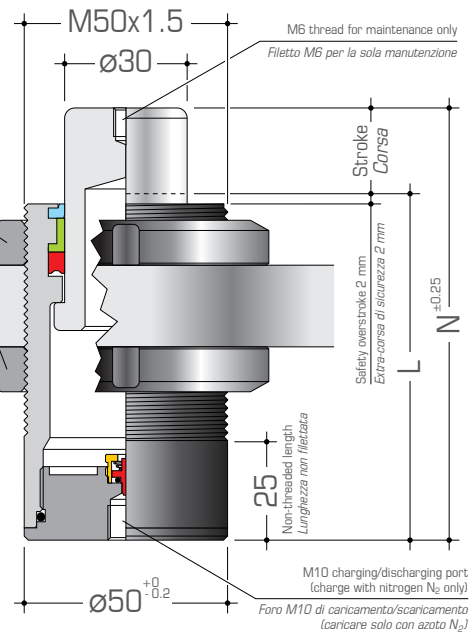

An internal thread M38x1.5 / M50x1.5 (ISO tolerance = 6H) must be properly machined into the support plate (the fastening rings are not designed for sustaining the load generated by the gas spring)

Un filetto interno M38x1.5 / M50x1.5 (tolleranza ISO = 6H) deve essere ricavato sulla piastra di supporto (le ghiera di fissaggio non sono progettate per sostenere il carico generato dal cilindro ad azoto)

MODEL MODELLO	MAX STROKE mm CORSA MAX mm	L mm	N mm	bar	daN	daN
CSMT38-10	10	55	65	197	750	1090
15	15	60	75			1130
25	25	70	95			1180
38	38	83	121			1230
50	50	95	145			1240
80	80	125	205			1280

MODEL MODELLO	MAX STROKE mm CORSA MAX mm	L mm	N mm	bar	daN	daN
CSMT50-10	10	60	70	212	1500	2460
25	25	75	100			2460
38	38	88	126			2510
50	50	100	150			2590
63	63	113	176			2590
80	80	130	210			2590
100	100	150	250	2650		

• Available on request / *Disponibili a richiesta*

• Two fastening rings are supplied with each gas spring / *Con ogni cilindro sono fornite due ghiera di fissaggio*

# Standard series

Nitrogen gas springs for press tools, dies and moulds / *Cilindri all'azoto per stampi*



## CHT

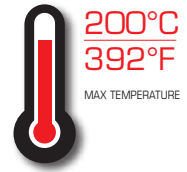

CHT series has been developed to work up to 200°C (392°F), for the most demanding high temperature applications.

The piston rod has to be lubricated with grease "PLUB".

*La serie CHT è stata sviluppata per lavorare fino a 200°C (392°F), per le più critiche applicazioni ad alta temperatura. Lo stelo deve essere lubrificato con grasso "PLUB".*

### Fixing possibilities

(see also our "Accessories for nitrogen gas springs for dies" catalogue)

### Fissaggi possibili

(vedi anche il nostro catalogo "Accessori per cilindri all'azoto per stampi")

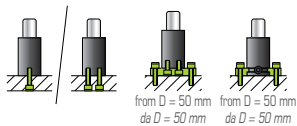

### CHT

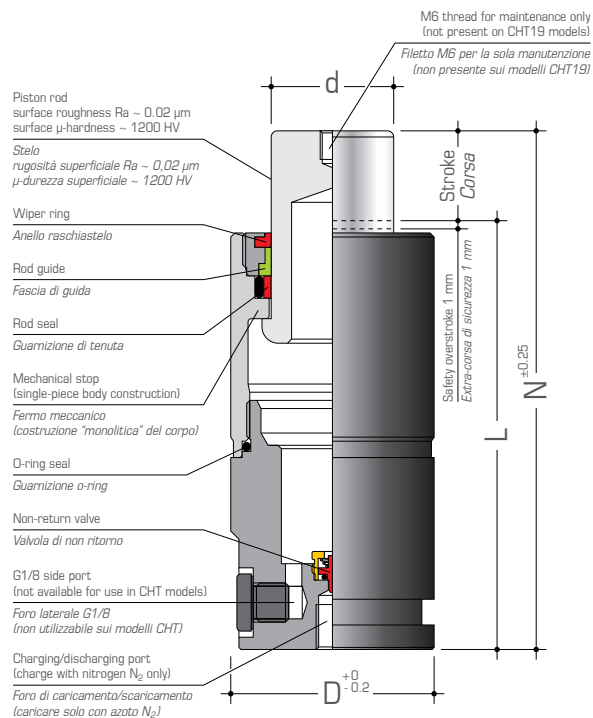

### TECHNICAL NOTES

#### Important use instructions and maximum number of cycles per minute on pages 10-17.

For accessories and other mountings, see the "Accessories for nitrogen gas springs for dies" catalogue.

#### ⚠ ATTENTION:

**Rod diameter  $d = 40$  mm for the CHT63 models (previous version:  $d = 36$  mm).**

### NOTE TECNICHE

#### Importanti istruzioni d'uso e numero massimo di cicli/minuto alle pagine 10-17.

Per accessori e altri montaggi, consultare il catalogo "Accessori per cilindri all'azoto per stampi".

#### ⚠ ATTENZIONE:

**Diametro dello stelo  $d = 40$  mm per i modelli CHT63 (versione precedente:  $d = 36$  mm).**

### HOW TO ORDER

**IMPORTANT:** it is necessary to contact our technical department in order to make sure that CHT gas springs are ok for the required application.

Bordignon technical department will send you a dedicated form to be filled with the application data.

(\* The **maximum charging pressure** (bar) depends on the use conditions (declared actual operating temperature).









You will be informed about the maximum charging pressure if your application is approved by our technical department.

### ESEMPIO D'ORDINE

**IMPORTANTE:** è necessario contattare il nostro ufficio tecnico per assicurarsi che i cilindri CHT siano adatti per l'applicazione richiesta. Il reparto Bordignon vi invierà un apposito modulo da compilare con i dati dell'applicazione.

(\* La **pressione massima di caricamento** (bar) dipende dalle condizioni di utilizzo (temperatura di lavoro effettiva dichiarata).

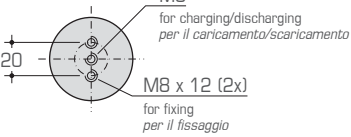
Sarete informati sulla massima pressione di caricamento se la vostra applicazione sarà accettata dal nostro ufficio tecnico.

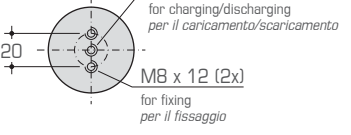
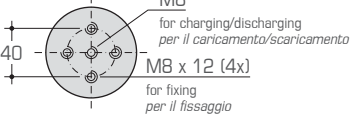
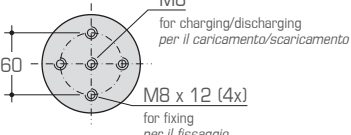
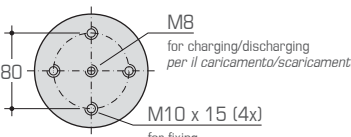
MODEL MODELLO	MAX STROKE mm CORSIA MAX mm	L mm	N mm	D mm	d mm	 bar (*)	 daN	 daN	GAS SPRING BASE BASE DEL CILINDRO
CHT19-10	10	70	80	19	10	See note (*) on page 46 Vedi nota (*) a pagina 46	100	130	 M8 x 14 for charging/discharging for fixing per il caricamento/scaricamento per il fissaggio
15	15	75	90					135	
25	25	85	110					140	
38	38	98	136					145	
50	50	110	160					155	
80	80	140	220					165	
CHT25-10	10	70	80	25	14	See note (*) on page 46 Vedi nota (*) a pagina 46	200	250	 M8 x 11 for charging/discharging for fixing per il caricamento/scaricamento per il fissaggio
15	15	75	90					270	
25	25	85	110					290	
38	38	98	136					320	
50	50	110	160					330	
80	80	140	220					350	
125	125	185	310					370	
CHT32-10	10	60	70	32	18	See note (*) on page 46 Vedi nota (*) a pagina 46	350	480	 M8 x 8 for charging/discharging for fixing per il caricamento/scaricamento per il fissaggio
15	15	65	80					490	
25	25	75	100					520	
38	38	88	126					530	
50	50	100	150					540	
80	80	130	210					550	
125	125	175	300					560	
160	160	210	370	570					
CHT38-10	10	65	75	38	22	See note (*) on page 46 Vedi nota (*) a pagina 46	500	650	 M8 x 9 for charging/discharging for fixing per il caricamento/scaricamento per il fissaggio
15	15	70	85					700	
25	25	80	105					750	
38	38	93	131					780	
50	50	105	155					800	
80	80	140	220					820	
125	125	185	310					840	
160	160	220	380					860	
200	200	260	460	880					
CHT50-10	10	95	105	50	30	See note (*) on page 46 Vedi nota (*) a pagina 46	1000	1250	 M8 for charging/discharging per il caricamento/scaricamento M8 x 12 (2x) for fixing per il fissaggio
25	25	110	135					1400	
38	38	123	161					1500	
50	50	135	185					1550	
63	63	148	211					1600	
80	80	165	245					1650	
100	100	195	295					1700	
125	125	220	345					1720	
160	160	255	415					1730	
200	200	295	495					1750	
250	250	345	595	1770					
CHT63-10	10	95	105	63	40 	See note (*) on page 46 Vedi nota (*) a pagina 46	1500	2200	 M8 for charging/discharging per il caricamento/scaricamento M8 x 12 (2x) for fixing per il fissaggio
25	25	110	135					2400	
38	38	123	161					2500	
50	50	135	185					2600	
63	63	148	211					2650	
80	80	165	245					2700	
100	100	185	285					2750	
125	125	220	345					2800	
160	160	255	415					2850	
200	200	295	495	2900					
CHT75-10	10	105	115	75	45	See note (*) on page 46 Vedi nota (*) a pagina 46	2500	3400	 M8 for charging/discharging per il caricamento/scaricamento M8 x 12 (4x) for fixing per il fissaggio
25	25	120	145					3800	
38	38	133	171					4200	
50	50	145	195					4300	
63	63	158	221					4400	
80	80	175	255					4450	
100	100	200	300					4500	
125	125	225	350					4550	
160	160	265	425					4650	
200	200	310	510	4800					
CHT95-25	25	130	155	95	58	See note (*) on page 46 Vedi nota (*) a pagina 46	4000	6200	 M8 for charging/discharging per il caricamento/scaricamento M8 x 12 (4x) for fixing per il fissaggio
38	38	143	181					6500	
50	50	155	205					6700	
63	63	168	231					6800	
80	80	190	270					6900	
100	100	210	310					7000	
125	125	245	370	7150					
CHT120-25	25	140	165	120	75	See note (*) on page 46 Vedi nota (*) a pagina 46	6500	9100	 M8 for charging/discharging per il caricamento/scaricamento M10 x 15 (4x) for fixing per il fissaggio
38	38	153	191					9700	
50	50	165	215					10000	
63	63	178	241					10400	
80	80	195	275					10700	

• Without G1/8 side hole and groove / Senza foro laterale G1/8 e scanalatura

• Available on request / Disponibili a richiesta

 Attention: see note on page 46 /  Attenzione: vedere nota a pag. 46

# Standard series

Nitrogen gas springs for press tools, dies and moulds / Cilindri all'azoto per stampi



## CSMHT

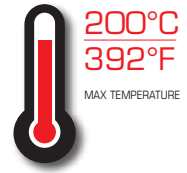

CSMHT compact series has been developed to work up to 200°C (392°F), for the most demanding high temperature applications.

The piston rod has to be lubricated with grease "PLUB".

La serie compatta CSMHT è stata sviluppata per lavorare fino a 200°C (392°F), per le più critiche applicazioni ad alta temperatura.

Lo stelo deve essere lubrificato con grasso "PLUB".

### CSMHT

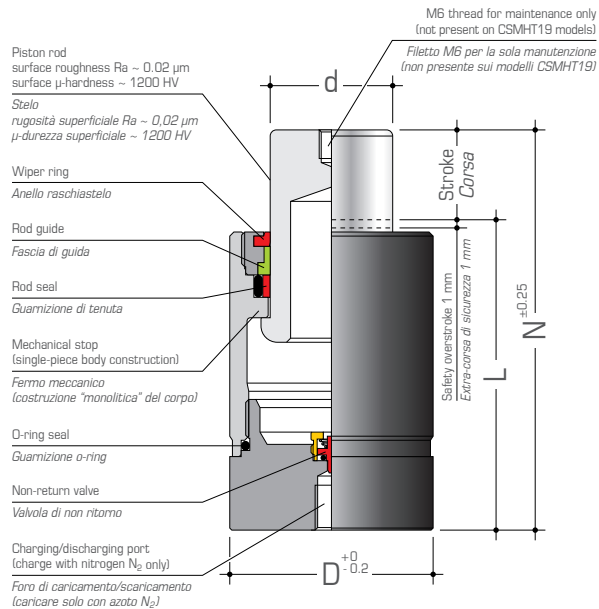

### Fixing possibilities

(see also our "Accessories for nitrogen gas springs for dies" catalogue)

### Fissaggi possibili

(vedi anche il nostro catalogo "Accessori per cilindri all'azoto per stampi")

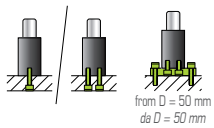

### TECHNICAL NOTES

#### Important use instructions and maximum number of cycles per minute on pages 10-17.

For accessories and other mountings, see the "Accessories for nitrogen gas springs for dies" catalogue.

#### ⚠ ATTENTION:

**Rod diameter d = 40 mm for the CSMHT63 models (previous version: d = 36 mm).**

### NOTE TECNICHE

#### Importanti istruzioni d'uso e numero massimo di cicli/minuto alle pagine 10-17.

Per accessori e altri montaggi, consultare il catalogo "Accessori per cilindri all'azoto per stampi".

#### ⚠ ATTENZIONE:

**Diametro dello stelo d = 40 mm per i modelli CSMHT63 (versione precedente: d = 36 mm).**

### HOW TO ORDER









**IMPORTANT:** it is necessary to contact our technical department in order to make sure that CSMHT gas springs are ok for the required application. Bordignon technical department will send you a dedicated form to be filled with the application data. (\*) The **maximum charging pressure** (bar) depends on the use conditions (declared actual operating temperature).

You will be informed about the maximum charging pressure if your application is approved by our technical department.

### ESEMPIO D'ORDINE

**IMPORTANTE:** è necessario contattare il nostro ufficio tecnico per assicurarsi che i cilindri CSMHT siano adatti per l'applicazione richiesta. Il reparto Bordignon vi invierà un apposito modulo da compilare con i dati dell'applicazione.

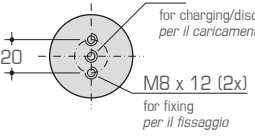
(\*) La **pressione massima di caricamento** (bar) dipende dalle condizioni di utilizzo (temperatura di lavoro effettiva dichiarata). Sarete informati sulla massima pressione di caricamento se la vostra applicazione sarà accettata dal nostro ufficio tecnico.

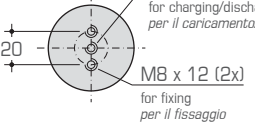
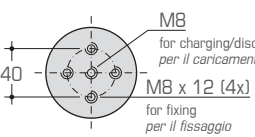
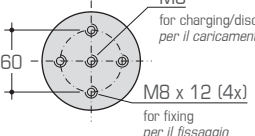
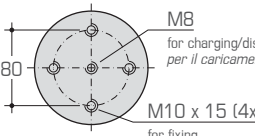
MODEL MODELLO	MAX STROKE mm CORSA MAX mm	L mm	N mm	D mm	d mm	 bar (*)	 daN	 daN	GAS SPRING BASE BASE DEL CILINDRO
CSMHT19-10	10	50	60	19	10	See note (*) on page 48 Vedi nota (*) a pagina 48	100	130	 M6 x 8 for charging/discharging for fixing per il caricamento/scaricamento per il fissaggio
15	15	55	70					140	
25	25	65	90					150	
38	38	78	116					160	
50	50	90	140					165	
80	80	120	200					170	
CSMHT25-10	10	50	60	25	14	See note (*) on page 48 Vedi nota (*) a pagina 48	200	290	 M6 x 8 for charging/discharging for fixing per il caricamento/scaricamento per il fissaggio
15	15	55	70					340	
25	25	65	90					350	
38	38	78	116					370	
50	50	90	140					380	
80	80	120	200					390	
125	125	165	290	400					
CSMHT32-10	10	55	65	32	18	See note (*) on page 48 Vedi nota (*) a pagina 48	350	490	 M6 x 8 for charging/discharging for fixing per il caricamento/scaricamento per il fissaggio
15	15	60	75					500	
25	25	70	95					530	
38	38	83	121					550	
50	50	95	145					570	
80	80	125	205					580	
125	125	170	295	590					
160	160	205	365	600					
CSMHT38-10	10	55	65	38	22	See note (*) on page 48 Vedi nota (*) a pagina 48	500	720	 M8 x 11 for charging/discharging for fixing per il caricamento/scaricamento per il fissaggio
15	15	60	75					750	
25	25	70	95					780	
38	38	83	121					820	
50	50	95	145					830	
80	80	125	205					850	
125	125	170	295	860					
160	160	205	365	870					
200	200	245	445	880					
CSMHT50-10	10	60	70	50	30	See note (*) on page 48 Vedi nota (*) a pagina 48	1000	1600	 M8 for charging/discharging per il caricamento/scaricamento M8 x 12 (2x) for fixing per il fissaggio
25	25	75	100					1630	
38	38	88	126					1670	
50	50	100	150					1690	
63	63	113	176					1700	
80	80	130	210					1710	
100	100	150	250	1720					
125	125	190	315	1730					
160	160	235	395	1740					
200	200	275	475	1750					
250	250	325	575	1760					
CSMHT63-10	10	65	75	63	40 	See note (*) on page 48 Vedi nota (*) a pagina 48	1500	2200	 M8 for charging/discharging per il caricamento/scaricamento M8 x 12 (2x) for fixing per il fissaggio
25	25	80	105					2400	
38	38	93	131					2500	
50	50	105	155					2550	
63	63	118	181					2600	
80	80	135	215					2650	
100	100	160	260	2700					
125	125	190	315	2750					
160	160	235	395	2800					
200	200	275	475	2900					
CSMHT75-10	10	65	75	75	45	See note (*) on page 48 Vedi nota (*) a pagina 48	2500	4000	 M8 for charging/discharging per il caricamento/scaricamento M8 x 12 (4x) for fixing per il fissaggio
25	25	80	105					4500	
38	38	93	131					4650	
50	50	105	155					4700	
63	63	118	181					4730	
80	80	135	215					4740	
100	100	155	255	4750					
125	125	200	325	4760					
160	160	250	410	4800					
200	200	300	500	4950					
CSMHT95-25	25	90	115	95	58	See note (*) on page 48 Vedi nota (*) a pagina 48	4000	6900	 M8 for charging/discharging per il caricamento/scaricamento M8 x 12 (4x) for fixing per il fissaggio
38	38	103	141					7050	
50	50	115	165					7150	
63	63	128	191					7180	
80	80	155	235					7200	
100	100	185	285					7250	
125	125	220	345	7400					
CSMHT120-25	25	100	125	120	75	See note (*) on page 48 Vedi nota (*) a pagina 48	6500	10300	 M8 for charging/discharging per il caricamento/scaricamento M10 x 15 (4x) for fixing per il fissaggio
38	38	113	151					10900	
50	50	125	175					11200	
63	63	138	201					11400	
80	80	160	240					11500	

\* Available on request / Disponibili a richiesta

 Attention: see note on page 48 /  Attenzione: vedere nota a pag. 48

# Standard series

Nitrogen gas springs for press tools, dies and moulds / Cilindri all'azoto per stampi



## CRAL

Slow-return self-contained gas springs, with adjustable length of the slow-down back stroke.

Cilindri autonomi a ritorno rallentato, con lunghezza regolabile della corsa di ritorno rallentata.

### CRAL

#### Fixing possibilities

(see also our "Accessories for nitrogen gas springs for dies" catalogue)

#### Fissaggi possibili

(vedi anche il nostro catalogo "Accessori per cilindri all'azoto per stampi")

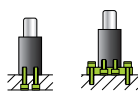

Piston rod surface roughness  $R_a \sim 0.02 \mu\text{m}$   
surface  $\mu\text{-hardness} \sim 1200 \text{ HV}$   
Stelo  
rugosità superficiale  $R_a \sim 0.02 \mu\text{m}$   
 $\mu\text{-durezza superficiale} \sim 1200 \text{ HV}$

G1/8 charging/discharging port  
(charge with nitrogen  $N_2$  only)  
Foro G1/8 di caricamento/scaricamento  
(caricare solo con azoto  $N_2$ )

"Needle-screw" for return stroke adjustment  
(to be operated with a 4 mm HEX key)  
"Vite-spillo" per regolare la corsa di ritorno  
(regolazione con chiave a brugola da 4 mm)

"Needle-screw" retaining screws  
(NEVER ATTEMPT TO UNSCREW)  
Viti di fermo/fine corsa per la "vite-spillo"  
(NON SVITARE MAI)

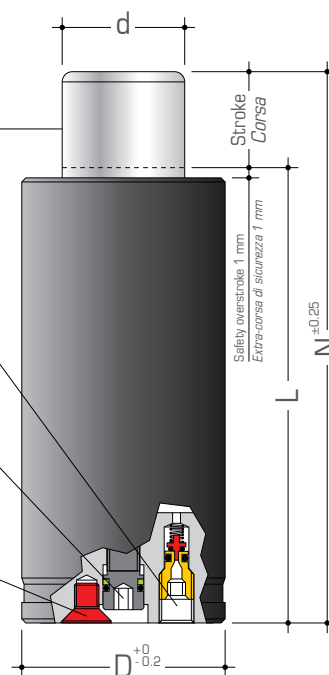

DIFFERENT CRAL TYPES / Working examples  
DIVERSI TIPI DI CRAL / Esempi di funzionamento

— PRESS — CRAL  
— Adjustable range (indicative)

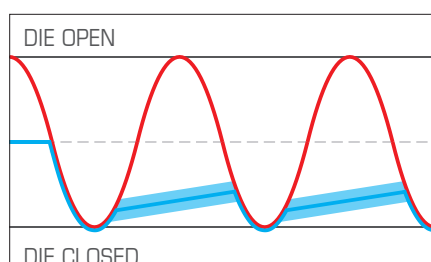
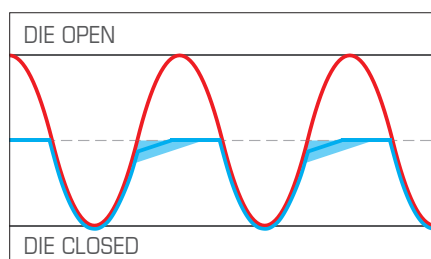
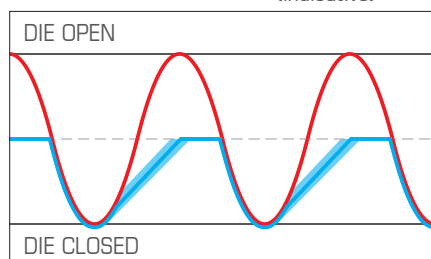

#### TECHNICAL NOTES

#### Important use instructions and maximum number of cycles per minute on pages 10-17.

The slow-return stroke length can be adjusted with the "needle-screw" at the gas spring bottom.

USE INSTRUCTIONS FOR CRAL GAS SPRINGS ARE PROVIDED WITH THE PRODUCT.

#### HOW TO ORDER

**IMPORTANT:** it is necessary to contact our technical department in order to make sure that CRAL gas springs can be used in the required application. Bordignon technical department will send you a dedicated form to be filled with the application data.

#### NOTE TECNICHE



#### Importanti istruzioni d'uso e numero massimo di cicli/minuto alle pagine 10-17.

La lunghezza della corsa frenata sul ritorno è regolabile con la "vite-spillo" alla base del cilindro.

LE ISTRUZIONI D'USO PER I CILINDRI CRAL SONO FORNITE CON IL PRODOTTO.

#### ESEMPIO D'ORDINE

**IMPORTANTE:** è necessario contattare il nostro ufficio tecnico per assicurarsi che i cilindri CRAL siano adatti per l'applicazione richiesta. Il reparto tecnico Bordignon vi invierà un apposito modulo da compilare con i dati dell'applicazione.

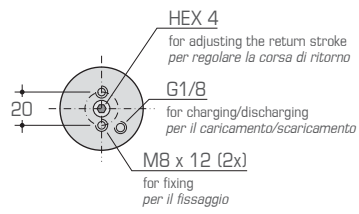
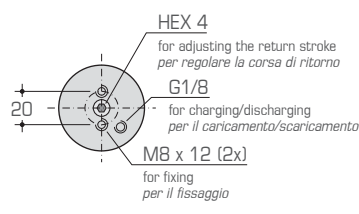
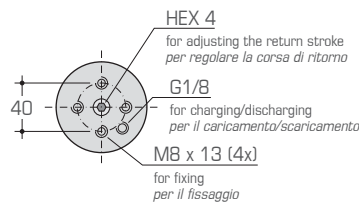
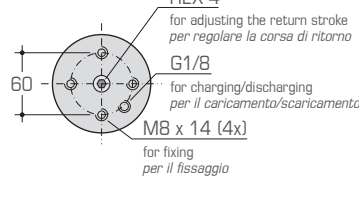
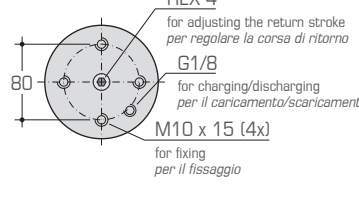
MODEL MODELLO	MAX STROKE mm CORSA MAX mm	L mm	N mm	D mm	d mm	 bar	 daN	 daN	GAS SPRING BASE BASE DEL CILINDRO
CRAL50-10	10	95	105	50	30	141	1000	1250	 <p>HEX 4 for adjusting the return stroke per regolare la corsa di ritorno</p> <p>G1/8 for charging/discharging per il caricamento/scaricamento</p> <p>20</p> <p>M8 x 12 (2x) for fixing per il fissaggio</p>
25	25	110	135					1400	
38	38	123	161					1500	
50	50	135	185					1550	
63	63	148	211					1600	
80	80	165	245					1650	
100	100	195	295					1700	
CRAL63-10	10	95	105	63	36	147	1500	2200	 <p>HEX 4 for adjusting the return stroke per regolare la corsa di ritorno</p> <p>G1/8 for charging/discharging per il caricamento/scaricamento</p> <p>20</p> <p>M8 x 12 (2x) for fixing per il fissaggio</p>
25	25	110	135					2400	
38	38	123	161					2500	
50	50	135	185					2600	
63	63	148	211					2650	
80	80	165	245					2700	
100	100	185	285					2750	
CRAL75-10	10	105	115	75	45	157	2500	3400	 <p>HEX 4 for adjusting the return stroke per regolare la corsa di ritorno</p> <p>G1/8 for charging/discharging per il caricamento/scaricamento</p> <p>40</p> <p>M8 x 13 (4x) for fixing per il fissaggio</p>
25	25	120	145					3800	
38	38	133	171					4200	
50	50	145	195					4300	
63	63	158	221					4400	
80	80	175	255					4450	
100	100	200	300					4500	
CRAL95-25	25	130	155	95	58	151	4000	6200	 <p>HEX 4 for adjusting the return stroke per regolare la corsa di ritorno</p> <p>G1/8 for charging/discharging per il caricamento/scaricamento</p> <p>60</p> <p>M8 x 14 (4x) for fixing per il fissaggio</p>
38	38	143	181					6500	
50	50	155	205					6700	
63	63	168	231					6800	
80	80	190	270					6900	
100	100	210	310					7000	
CRAL120-25	25	140	165	120	75	147	6500	9100	 <p>HEX 4 for adjusting the return stroke per regolare la corsa di ritorno</p> <p>G1/8 for charging/discharging per il caricamento/scaricamento</p> <p>80</p> <p>M10 x 15 (4x) for fixing per il fissaggio</p>
38	38	153	191					9700	
50	50	165	215					10000	
63	63	178	241					10400	
80	80	195	275					10700	
100	100	215	315					10900	



## OV

Valveless nitrogen gas springs,  
for an alternative manifold connection:

- » use of standard gas springs, fast delivery!
- » lower manufacturing and maintenance costs than traditional manifold plates and dedicated manifold gas springs;
- » more compact plate dimensions;
- » simple gas spring fixing with through-plate screws;
- » OV gas springs available strokes, dimensions, and the other specifications not listed on page 53, are the same as the corresponding standard models (example: SMLXOV38-50 unlisted specifications as SMLX38-50).

*Cilindri all'azoto senza valvola,  
per una connessione manifold alternativa:*

- » *uso di cilindri standard, rapida consegna!*
- » *costi di produzione e manutenzione più contenuti rispetto a piastre manifold tradizionali e cilindri manifold dedicati;*
- » *dimensioni delle piastre più contenute;*
- » *semplice fissaggio dei cilindri con viti attraverso la piastra;*
- » *corse disponibili, dimensioni, e le altre specifiche dei cilindri OV non elencate a pagina 53, sono le stesse dei rispettivi modelli standard (esempio: per le specifiche non elencate del modello SMLXOV38-50, vedere il modello SMLX38-50).*

A



### USE EXAMPLES / TECHNICAL NOTES

- A OV valveless gas springs fixed on a single low-thickness plate, without connection tubes.
- B OV valveless gas springs fixed on smaller plates connected by tubes.
- C For accessories see the "Accessories for nitrogen gas springs for dies" catalogue.

### ESEMPI D'USO / NOTE TECNICHE

- A *Cilindri senza valvola OV fissati ad una singola piastra di spessore contenuto, senza tubi di collegamento.*
- B *Cilindri senza valvola OV fissati a piastre più piccole collegate con tubi.*
- C *Per gli accessori consultare il catalogo "Accessori per cilindri all'azoto per stampi".*

**Important use instructions and maximum number of cycles per minute on pages 10-17.**

**Importanti istruzioni d'uso e numero massimo di cicli/minuto alle pagine 10-17.**

### How to order

### Esempio d'ordine

#### 8 CSMXOV50-10 1500daN

No. 8 valveless nitrogen gas springs CSMXOV  
ø 50 mm, stroke 10 mm,  
max initial force 1500 daN, with OR 2021.

#### 8 CSMXOV50-10 1500daN

*N° 8 cilindri all'azoto senza valvola CSMXOV  
ø 50 mm, corsa 10 mm, massima forza iniziale  
1500 daN, con OR 2021.*

#### 8 SMLXOV50-10

No. 8 valveless nitrogen gas springs SMLXOV  
ø 50 mm, stroke 10 mm, max initial force  
1500 daN, with OR 114 and bonded seal 764  
for special screw.

#### 8 SMLXOV50-10

*N° 8 cilindri all'azoto senza valvola SMLXOV ø  
50 mm, corsa 10 mm, massima forza iniziale  
1500 daN, con OR 114 e rondella di tenuta  
764 per vite speciale.*

PRICE ON REQUEST

PREZZO A RICHIESTA

B

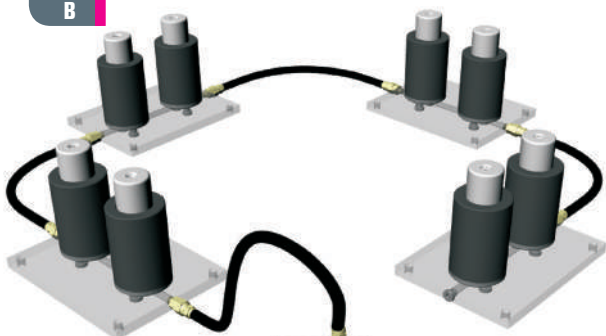

C

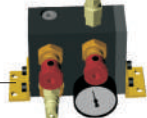

MULTIPLE-THREAD GAS SPRING FIXING

FISSAGGIO DI CILINDRI CON PIÙ FORI FILETTATI

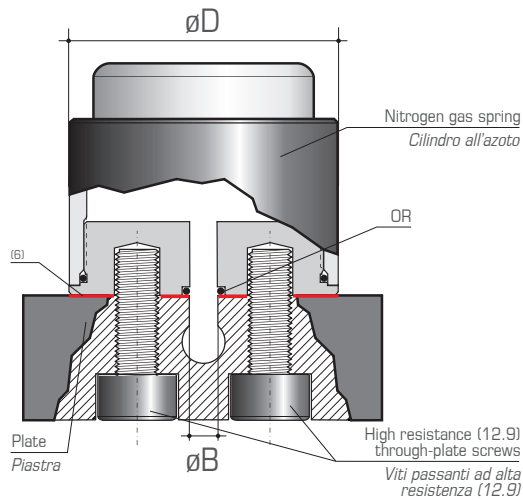

MODEL MODELLO	Ø		OR 90 Sh. A
	B <sup>(3)</sup> MAX mm	D <sup>(4)</sup> MIN mm	
CSXOV32- ...	2.5	32	2015
2XCSXOV32- ...	2.5	32	2015
CSXOV38- ...	3	38	2021
50- ...	3	50	2021
63- ...	3	63	2021
75- ...	4	75	3030
95- ...	4	95	3030
CSMXOV50- ...	3	50	2021
63- ...	3	63	2021
75- ...	4	75	3030
95- ...	4	95	3030
120- ...	4	120	3030

• One OR is supplied with each nitrogen gas spring / Con ogni cilindro è fornito un OR

Stroke lengths availability and other specifications: see CSX, 2XCSX and CSMX standard series  
Corse disponibili e altre specifiche tecniche: vedi le serie standard CSX, 2XCSX e CSMX

SINGLE-THREAD GAS SPRING FIXING

FISSAGGIO DI CILINDRI CON SINGOLO FORO FILETTATO

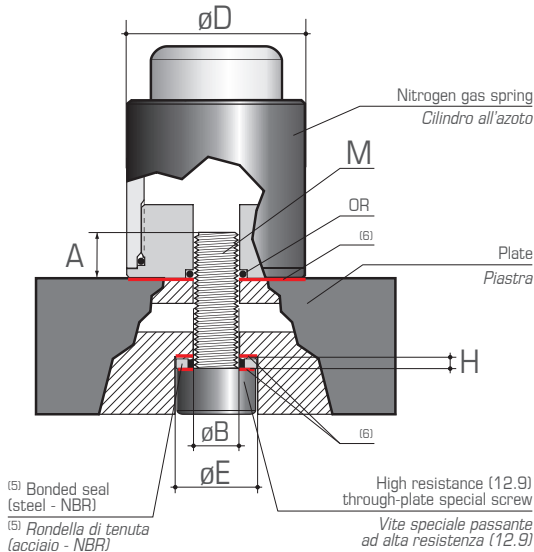

MODEL MODELLO	M <sup>(1)</sup>	A <sup>(2)</sup> (+1 0)	Ø			H	OR 90 Sh. A	BONDED SEAL <sup>(5)</sup>
		mm	B <sup>(3)</sup> MAX mm	D <sup>(4)</sup> MIN mm	E <sup>(4)</sup> MIN mm	mm		
CSMXOV19- ...	M6	9	6	19	12	1.5	2031	898
SMLXOV25- ...	M6	9	6	25	12	1.5	2031	898
32- ...	M6	9	6	32	12	1.5	106	898
38- ...	M8	12	8	38	15	1.5	2043	866
50- ...	M10	15	10	50	18	2	114	708
63- ...	M10	15	10	63	18	2	114	708
75- ...	M12	18	12	75	21	2	2056	867
95- ...	M12	18	12	95	21	2	2056	867
120- ...	M16	24	16	120	27	2	2075	870

• One OR and one bonded seal is supplied with each nitrogen gas spring / Con ogni cilindro è fornito un OR e una rondella di tenuta

Stroke lengths availability and other specifications: see CSMX and SMLX standard series  
Corse disponibili e altre specifiche tecniche: vedi le serie standard CSMX e SMLX

TECHNICAL NOTES

NOTE TECNICHE

- 1) Special screw thread.
- 2) Special screw screwing depth inside the gas spring.
- 3) Plate hole maximum diameter.
- 4) Minimum finished surface area diameters for seals/plate coupling.
- 5) Steel - NBR bonded seals.
- 6) RED LINES IN THE DRAWINGS SHOW THE SURFACES TO BE FINISHED (GRINDED) FOR SEALS/PLATE COUPLING.

- 1) Filetto della vite speciale.
- 2) Profondità di avvitamento della vite speciale all'interno del cilindro.
- 3) Diametro massimo foro piastra.
- 4) Diametri minimi delle aree ad alta finitura per l'accoppiamento guarnizioni/piastra.
- 5) Rondelle di tenuta in acciaio - NBR.
- 6) LE LINEE ROSSE NEI DISEGNI RAPPRESENTANO LE SUPERFICI DA RETTIFICARE PER L'ACCOPPIAMENTO GUARNIZIONI/PIASTRA.

# Standard series

Nitrogen gas springs for press tools, dies and moulds / Cilindri all'azoto per stampi

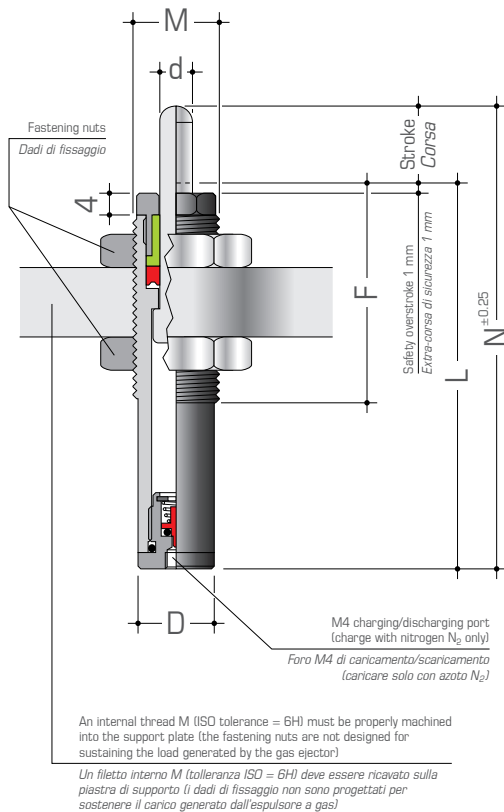
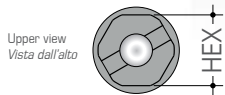

## Fixing possibilities

(see also our "Accessories for nitrogen gas springs for dies" catalogue)

## Fissaggi possibili

(vedi anche il nostro catalogo "Accessori per cilindri all'azoto per stampi")



## Fastening nuts / Dadi di fissaggio

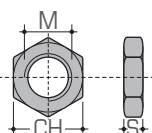

MODEL MODELLO	M mm	S mm	CH mm
EG-D-16	M16 x 1.5	8	24
EG-D-24	M24 x 1.5	10	36

## Special key / Chiave speciale



MODEL MODELLO	FOR PER
EG-CH-16	EG16
EG-CH-24	EG24

# EG

The EG lifters are charged with nitrogen gas. The charging pressure can be from the minimum of 20 bar to the maximum of 150 bar, with the corresponding forces shown in the table. Any intermediate force can be requested with the order, thus receiving them charged and ready-to-use.

Gli EG sono espulsori caricati con azoto. La pressione di carico può essere compresa tra un minimo di 20 bar ed un massimo di 150 bar, con le forze corrispondenti come da tabella. Qualsiasi forza iniziale intermedia può essere richiesta nell'ordine, avendoli così già caricati e pronti per l'uso.

## HOW TO ORDER

### No. 8 pcs. EG16-10 42daN

No. 8 nitrogen gas ejectors series EG with threaded body M16 x 1.5 stroke length = 10 mm, initial force = 42 daN.

## ESEMPIO D'ORDINE

### No. 8 EG16-10 42daN

N° 8 espulsori a gas azoto serie EG con corpo filettato M16 x 1,5 corsa = 10 mm, forza iniziale = 42 daN.

## TECHNICAL NOTES

Important use instructions and maximum number of cycles per minute on pages 10-17.

## NOTE TECNICHE

Importanti istruzioni d'uso e numero massimo di cicli/minuto alle pagine 10-17.

(\* Final force (force at full stroke) = Initial force x R

(\* Forza finale (forza a fine corsa) = Forza iniziale x R

MODEL MODELLO	L mm	N mm	d mm	F mm	D mm	M	HEX mm	daN 20bar	daN 150bar	R (*)
EG16-10	70	80								1.1
20	80	100								1.3
30	90	120								1.3
40	100	140								1.4
50	110	160	6	40	14	M16x1.5	13	6	42	1.5
60	120	180								1.7
70	130	200								1.8
80	140	220								1.9
100	160	260								2.0
EG24-10	70	80								1.2
20	80	100								1.4
30	90	120								1.5
40	100	140								1.5
50	110	160	12	45	22	M24x1.5	19	23	170	1.6
60	120	180								2.0
70	130	200								2.0
80	140	220								2.2
100	160	260								2.4

# Standard series

Ejectors for press tools, dies and moulds / *Espulsori per stampi*



## EM

The EM are wire spring ejectors. They have lower force than EG lifters.

*Gli EM sono espulsori a molla. Hanno forze inferiori agli espulsori a gas EG.*

### Fixing possibilities

(see also our "Accessories for nitrogen gas springs for dies" catalogue)

### Fissaggi possibili

(vedi anche il nostro catalogo "Accessori per cilindri all'azoto per stampi")



### LIGHT FORCE SERIES

### SERIE LEGGERA

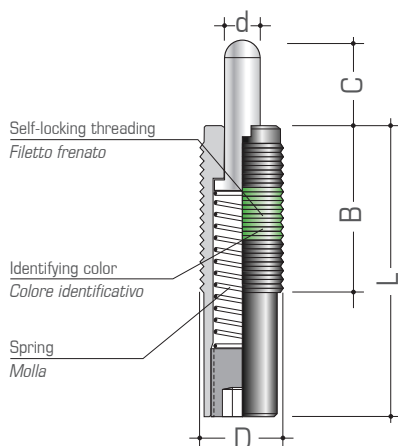

MODEL MODELLO	D	C mm	L mm	B mm	d mm	INITIAL FORCE FORZA INIZIALE daN	FINAL FORCE FORZA FINALE daN
EM12-10G	M12x1.75	10	43	35	5.5	0.4	2
EM16-10G	M16x2	10	60	35	7.5	1.3	4
15G		15	60			1.0	
20G		20	80			1.3	
30G		30	125			1.8	
40G		40	150			1.3	
50G	50	150	1.3				
EM24-15G	M24x3	15	60	45	10	2.0	10

### HEAVY FORCE SERIES

### SERIE FORTE

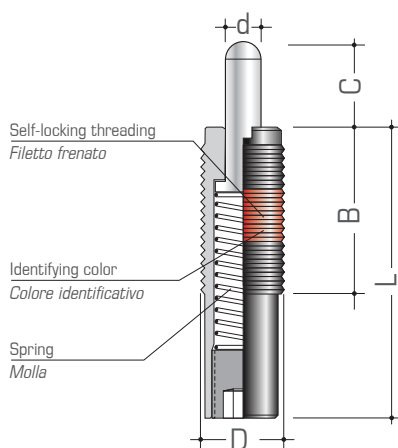

MODEL MODELLO	D	C mm	L mm	B mm	d mm	INITIAL FORCE FORZA INIZIALE daN	FINAL FORCE FORZA FINALE daN
EM12-10R	M12x1.75	10	43	35	5.5	0.7	4
EM16-10R	M16x2	10	60	35	7.5	2.7	8
15R		15	60			1.5	
20R		20	80			1.7	
30R		30	125			2.0	
40R		40	150			2.6	
50R	50	150	2.6				
EM24-15R	M24x3	15	60	45	10	4.0	20

### Special key / Chiave speciale



MODEL FOR  
MODELLO PER

EG-CH-12 EM12

EG-CH-16 EM16

EG-CH-24 EM24



**BORDIGNON SRL**

Via Volta, 20  
36028 Rossano Veneto (VI) Italy  
T +39 0424 36157  
F +39 0424 382359  
bordignon@bordignon.com  
www.bordignon.com

**PRODUCTION / TECHNICAL OFFICE \***

Zona Industriale  
38055 Grigno (TN) Italy  
T +39 0461 765488  
F +39 0461 775503  
bordignon@bordignon.info

[www.bordignon.com](http://www.bordignon.com)

For gas spring accessories and other Bordignon high quality products, take a look at our other catalogues.

Per gli accessori per cilindri e altri prodotti di alta qualità Bordignon, consultate gli altri nostri cataloghi.



Accessories for nitrogen gas springs  
*Accessori per cilindri all'azoto*



ISO 10243 die springs  
*Molle per stampi ISO 10243*



In-die tapping unit, out-die tapping unit  
*Maschiatrice in e fuori stampa*



Minimal lubrication pump  
*Pompa di lubrificazione minimale*



Air scrap remover  
*Evacuatore di sfridi ad aria*



BORDIGNON Srl reserves the right to make modifications to the technical data of this catalogue, without prior notice  
*BORDIGNON Srl si riserva la facoltà di apportare, senza preavviso, eventuali modifiche tecniche ai prodotti di questo catalogo.*