

Blanks for cold forming

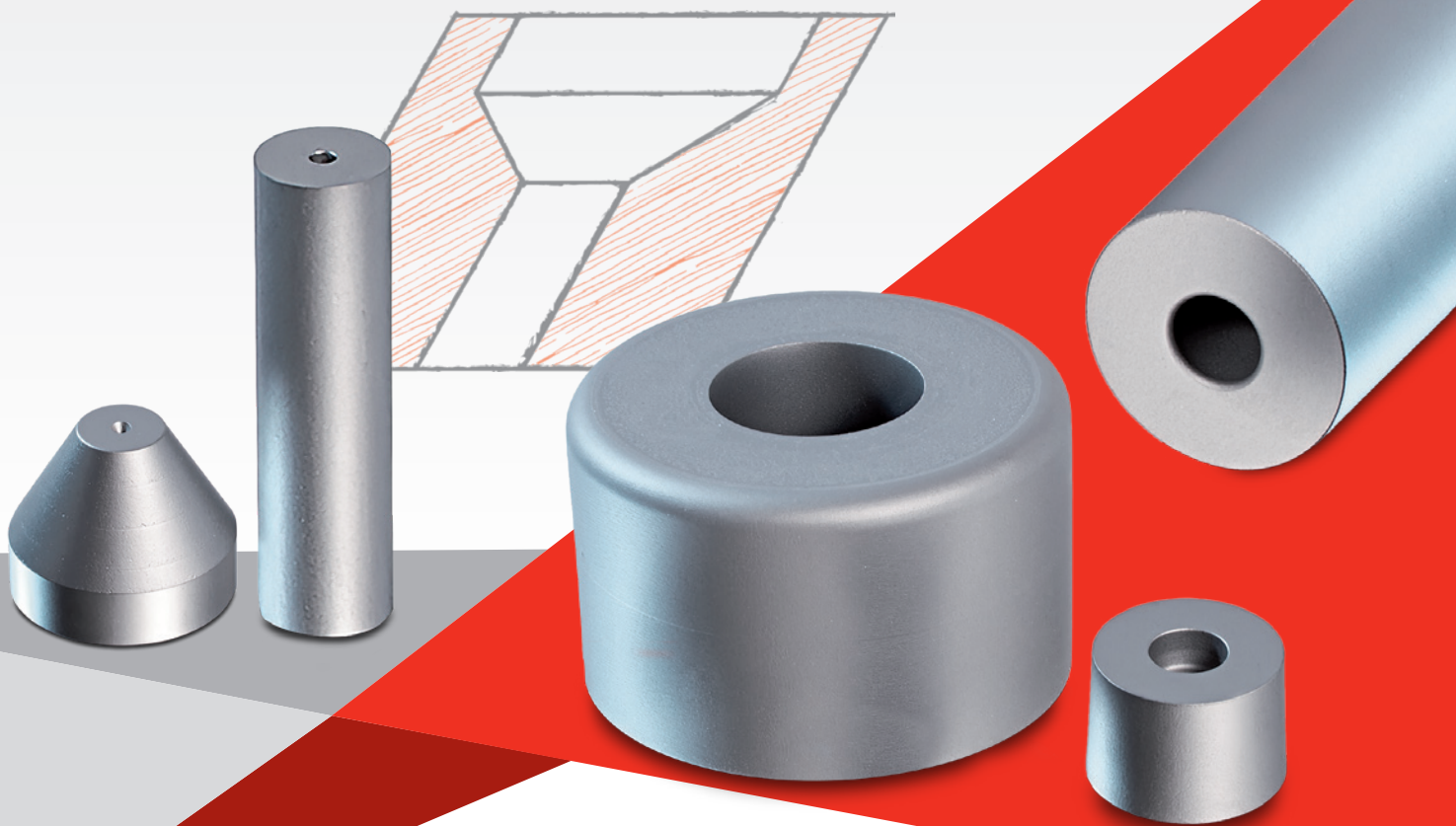



As we manage the entire process chain, we can always guarantee top quality and smooth collaboration.

Custom blanks and semifinished products exactly according to your requirements: fast, flexible, straightforward

CERATIZIT offers a wide range of custom blanks and semi-finished products for a variety of applications. Our long-time customers particularly appreciate our short response and delivery times, as well as the diverse production possibilities with high precision according to our BCF - Blanks for Cold Forming configurator. Thanks to both our production lines (fast line and standard line), we can serve the market with fast deliveries, small batches and constant high quality.

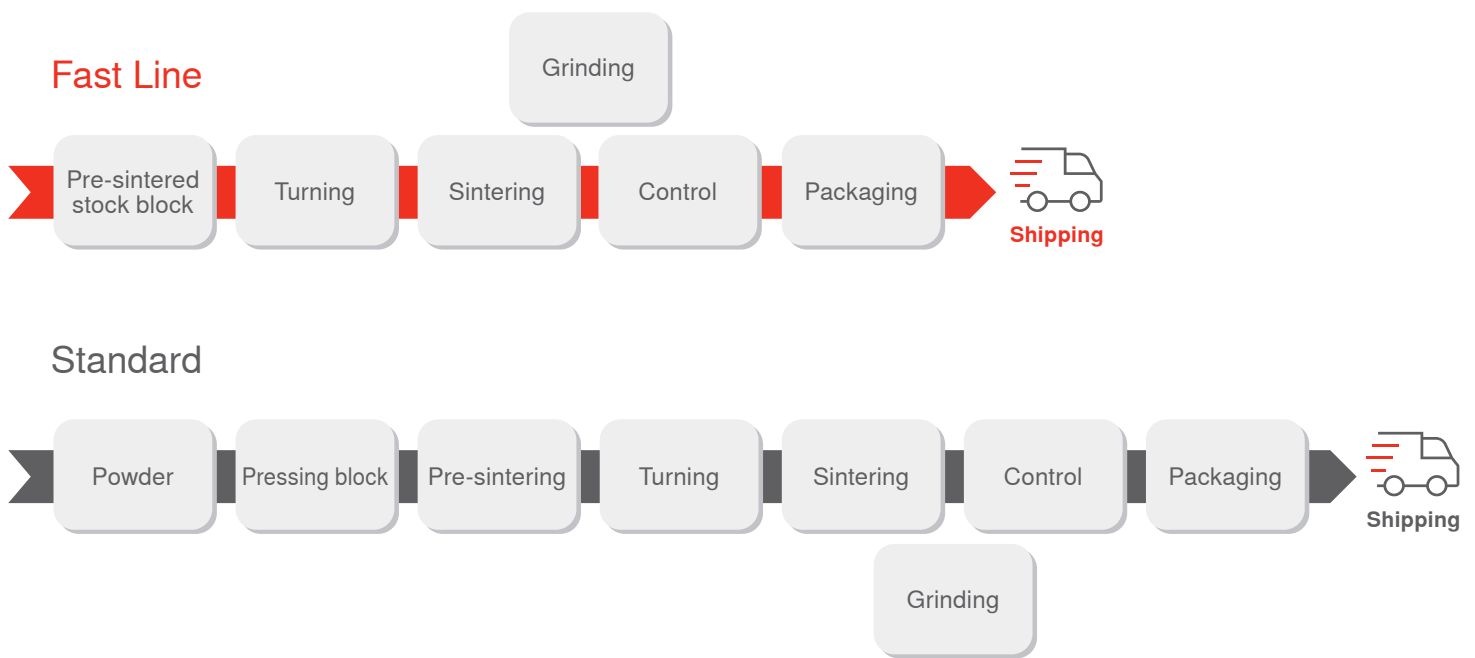

Example of standard configurable geometries

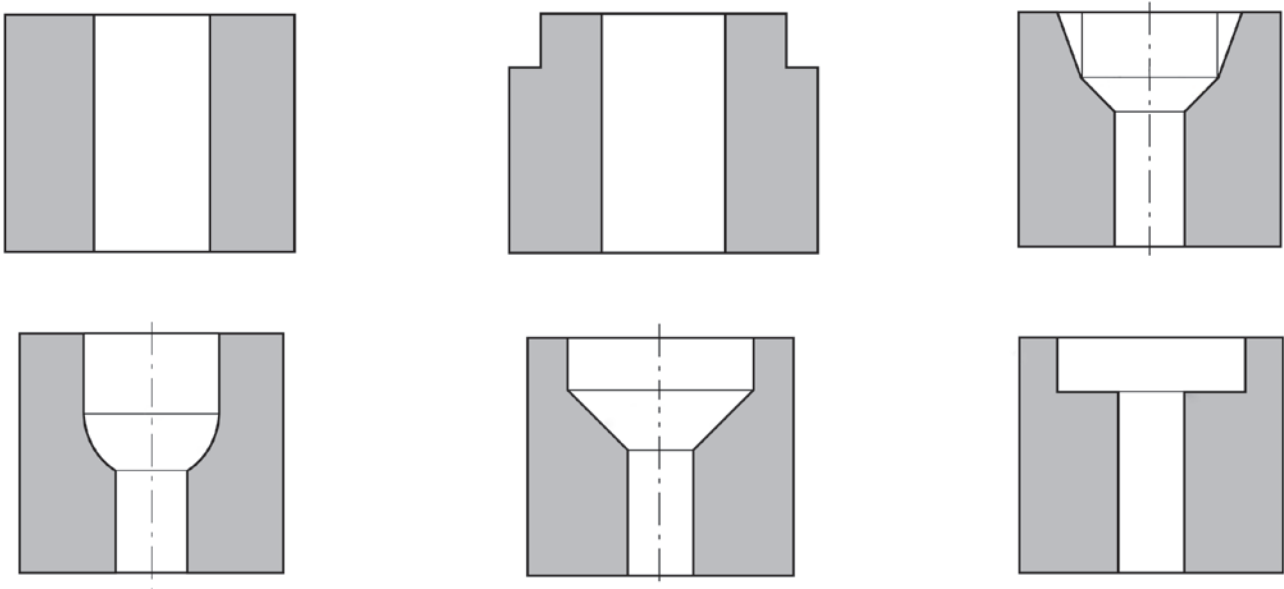

Online product configurator

Just a few clicks to create your very own individual product

Configuration, ordering, production and delivery are consistently integrated in a highly automated process. Design your individual carbide blanks and tools online with just a few clicks in our E-Techstore to speed up your supply chain process! Now even easier, faster and more reliable. Our configurator is available for many different product groups and we are constantly extending our offering.



OUR SERVICE

- ▲ **Your order in a few steps:**
First you enter the finished dimensions. You will see a 2D drawing visualisation with the dimensions you have entered. In this way you can check your entries speedily and securely.
- ▲ **You then receive an immediate offer** on the exact conditions you have specified.
- ▲ **Digital production for the future:**
Your order data are directly transmitted to our ERP system which produces all the production parameters needed. Automatic production starts immediately after your order has been placed.
- ▲ **We are constantly extending our configurator offering. Currently it is possible to order**
 - Blanks for hobs
 - Circular tooling blanks
 - Rotary cutters for the sanitary industry
 - Blanks for cold forming
 - Solutions for the fastening industry



YOUR BENEFITS

- ▲ **Order individual blanks and tools easily – 24/7:**
With just a few clicks you will receive an offer of your customised blanks and tools. Your offers are saved along with the design data – you can place the order immediately or come back later. Wherever and whenever you want.
- ▲ **Configure your dimensions quickly and safely:**
Simply enter the finished dimensions and rapidly compare the visualised part with the data you have entered. You immediately get an automatically generated offer, including a delivery date.
- ▲ **Excellent support:** When needed, our experts can intervene to support you personally. We have an online tutorial available to show you all the possibilities and features of the configurator.

Advantages & benefits

Strong arguments for tailor-made carbide solutions from CERATIZIT.



Advantages

Production of small batch sizes in no time

Near net shape production possible depending on part and grade, small components made from material with low cobalt content can be manufactured without grinding allowance

In-house development, manufacturing and detailed quality analysis within the CERATIZIT Group guarantees highest product quality

Centre of excellence for carbides with high cobalt content

Consistent processes in production and know-how accumulated over decades in all manufacturing and machining technologies

Benefits

> Quick and flexible delivery reduces inventory costs

> Economical and quick machining of carbide blanks and semi-finished products

> High-quality and individually adapted carbide grades guarantee long tool life and save on production costs

> Individual development and high-precision production possible according to customer drawings; consulting in design development to optimise the application

> Low tolerances and consistent quality of the blanks as well as stable forming processes at the same parameters

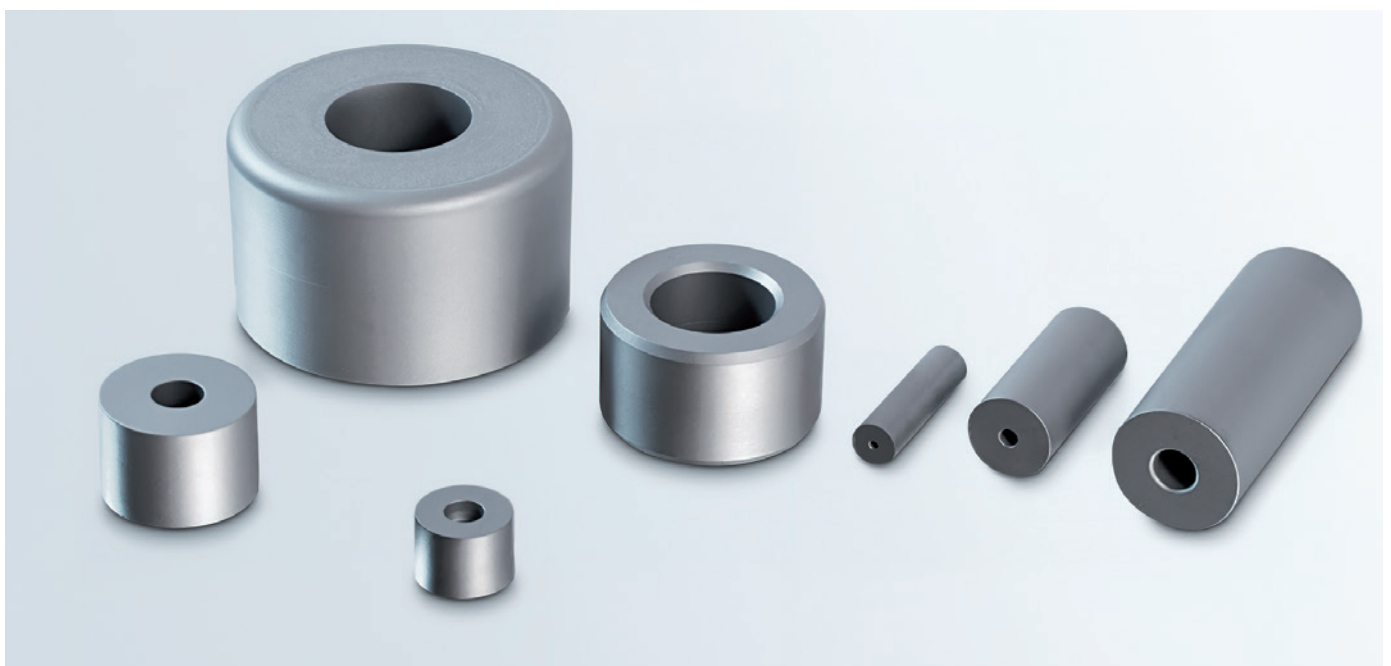

Diverse carbide blanks

CERATIZIT offers a wide range of diverse carbide blanks. In addition to the standard type (round with cylindrical hole), our portfolio also features small parts, long and thin components, thinwalled sleeves, but also complex components with complicated profiles.

Product portfolio:

- ▲ Standard configurable blanks and pre-ground articles
- ▲ Customized blanks for metal forming

Grade table

CERATIZIT grade code	ISO code	Binder [m %]	Hardness			Transverse rupture strength		Fracture toughness KIC [MPa·m ^{1/2}]
			[HV10]	[HV30]	[HRA]	[MPa]	[P.S.I]	
CTS12	K05-K10	6.0	1820	1790	93.0	3500	508.000	8.2
CTS20	K20-40	10.0	1610	1590	91.9	3700	537.000	10.1
CTS30	>K40	15.0	1330	1320	89.7	3800	552.000	11.9
CTF12	K20 / G10	6.0	1640	1620	92.1	2200	319.000	9.9
CTF24	K40	12.0	1330	1320	89.7	3000	435.000	12.0
CTF30	>K40 / G30	15.0	1250	1240	88.8	3100	450.000	13.1
CTF40	G40	20.0	1070	1060	86.8	3400	493.000	18.0
CTF54	>G50	27.0	920	910	84.8	3200	464.000	22.0
CTM17		8.5	1420	1400	90.4	2800	406.000	11.3
CFG-CTM30		15.0	1160	1150	87.9	2950	428.000	17.5
CFG-CTM40		20.0	1010	1000	87.3	3150	457.000	21.0
CFG-CTM50		25.0	860	850	84.3	3100	450.000	23.5
CTE20	G20	10.0	1130	1120	87.6	2600	377.000	18.0
CTE30	G30	15.0	970	960	85.6	2800	406.000	22.0
CTE40	G40	20.0	850	840	84.2	2900	421.000	24.0
CTE50	G50	25.0	760	750	82.6	2800	406.000	26.0
CTE60	G60	30.0	690	680	81.4	2700	331.000	27.0

Fast-paced high quality

We can produce a vast variety of components, big and small. Near net shape is a must, so additional complicated and cost-intensive finishing operations are no longer necessary. We have streamlined our process to produce the configurable geometries. Production of customized parts according to 2D customer drawings and specifications is also possible. We use modern CAD/CAM solutions to transfer data and geometries directly to our machines in the production. We control the complete supply chain of our materials, from the mines to the preparation of the ready to press powder. This way we can always ensure high and consistent quality of our materials. To offer our customers the most innovative and the most durable solutions possible, our development activities on materials are always running in our R&D centre.

Application areas

Blanks from CERATIZIT are particularly suited for the following materials:

- ▲ Stainless and non-stainless steels
- ▲ Non-ferrous metals

Our products can be used in a broad range of industries, e.g.

- ▲ Mechanical engineering industry
- ▲ Automotive industry
- ▲ Medical systems
- ▲ Wire production
- ▲ Electric and electronic industry
- ▲ Nail and rivet production
- ▲ Mining, road construction
- ▲ Bearings industry
- ▲ Tool and die construction



Sophisticated

In close collaboration with our customers, we also create 3D models wherever necessary in order to clarify technical questions before production and to thereby secure an optimal end result. We use modern turning and milling machines for complex components. There are almost no restrictions to our production, as we can machine components on up to five axes simultaneously.

Passion for cemented carbide

From the ore to the ready-to-use-tool

CERATIZIT is one of the few carbide manufacturers who manages the entire process chain singlehandedly: from ore extraction to the ready-to-use product. In the different areas that are involved, our highly qualified experts are familiar with every single step of the production process. With our ultra-modern machine park and great manufacturing depth, we guarantee that you will be able to count on a strong partner.

To ensure the high quality of our products and the environmental friendliness of our production methods, our processes are certified to DIN ISO 9001 standards. What this means for you is that you will find the sum of all the skills of the entire CERATIZIT Group combined in each one of our products.

We manage the entire process chain



Online shop

Conveniently shop online all around the clock.

Our online shop is your 24/7 online access to CERATIZIT products: an intuitive and user-friendly design, with clearly structured categories and filter functions, makes it easy to search and find the products you are looking for.

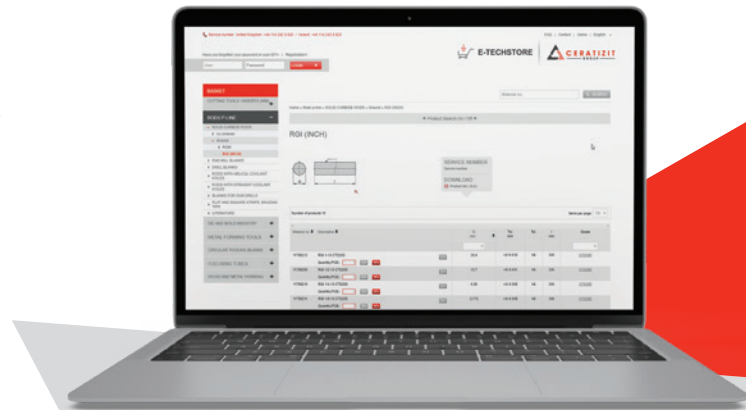

Your advantages



Availability

Shop our large assortment of over 25,000 products online. You will get instant information about availability and real-time stock updates from our warehouses all over the world.



Support

You won't be left on your own. Our customer service and sales teams are always here to answer your questions before, during and after your purchase. All details of your personal contact at CERATIZIT are just one click away.



Our online shop is available 24/7 for you!



Configurator

If you are looking for a customer-specific piece that you can't find in the standard range, our online product configurator makes it easy to design a broad variety of tools and components to meet your needs.



Documentation

Find all your on- and offline transactions in one place (quotations, orders, invoices etc.) with tracking and tracing of your shipment history.



Information

Get detailed information about our products, including CAD data, technical drawings and images, with filters for an easy product search.



User management

Benefit from a multi-user system where you can decide which level of authorisation a user should have, depending on the role within your company.

Hard Material Solutions

Hard cases are our speciality

We are your ideal partner when it comes to **high-quality hard materials for production processes, tool manufacturing and wear protection.**

From standard products to tailor-made solutions, from massive components to minute parts, from the blank to the fully finished product – a product that meets the highest standards of precision, surface treatment, and user-friendly assembly – our carbide and ceramic solutions ensure improved efficiency and outstanding total cost of ownership.

This is the case in a variety of application fields and industrial sectors. Even when subjected to extreme stress, our cemented carbides are notable for the high flexibility they offer in numerous industries. Our products are specially designed for extreme working conditions, making our Hard Material Solutions impressive tools for optimising your processes and increasing wear resistance.

Product portfolio

- ▲ Blanks and semi-finished products
- ▲ Water-jet cutting
- ▲ Hob milling
- ▲ Drawing tools & drawing nibs

Solutions for:

- ▲ Tool & die
- ▲ Fastening industry
- ▲ Injection technology
- ▲ Health industry
- ▲ Plastics industry

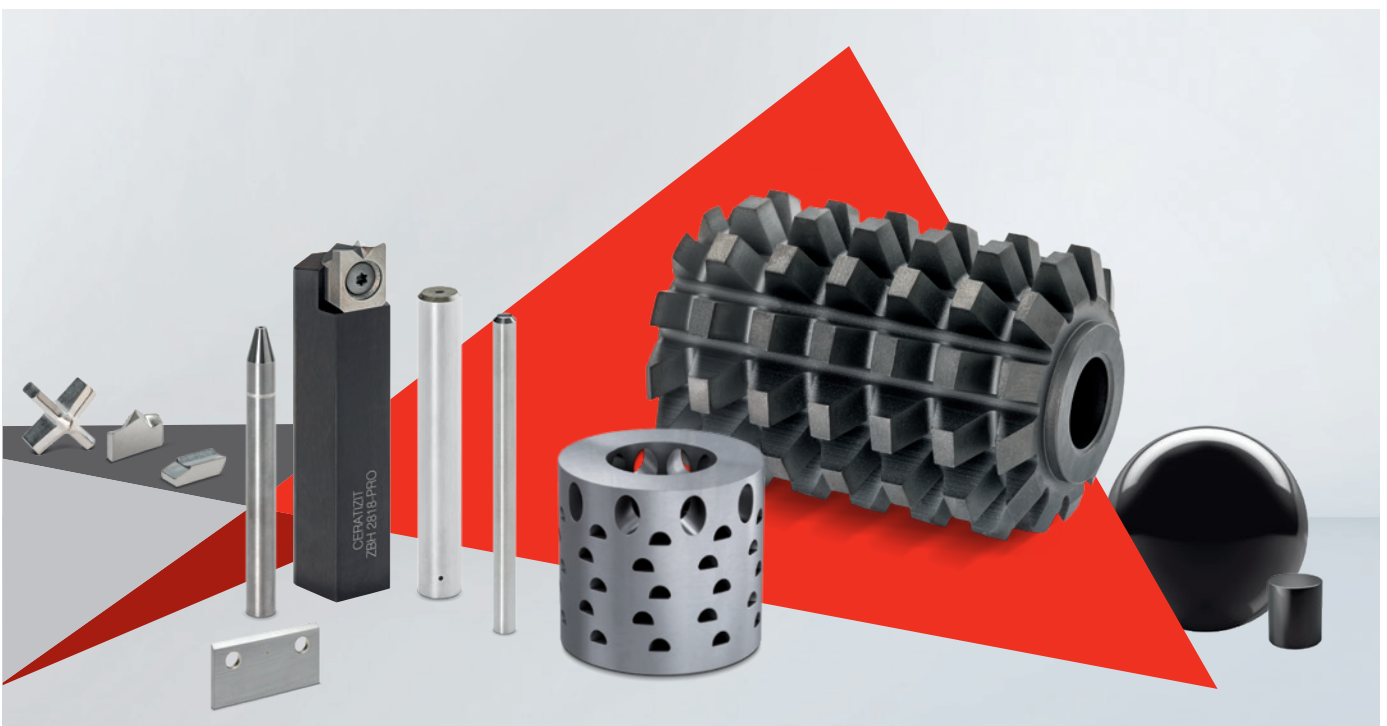

CERATIZIT Group

For over 100 years, CERATIZIT has been a pioneer in developing exceptional hard material solutions for machining and wear protection. The private company, with registered offices in Mamer, Luxembourg, develops and produces highly specialised cutting tools, indexable inserts, rods made from hard materials and wear parts.

The CERATIZIT Group is the global market leader in various application segments and successfully develops new carbide, cermet and ceramic grades, such as for wood and stone working.

Facts & figures

 **Headquarters**
Mamer, **Luxembourg**

 **30** more than
production sites

 **8 000** more than
employees

 **80** more than
countries in which we are active

 **1 00 000** more than
products

 **1 000** more than
patents & utility models

 **2 00** more than
R&D employees

 **35** % of products
developed in the last 5 years

 **20** more than
innovation awards

Headquarters

CERATIZIT S.A.
LU-8232 Mamer
T. +352 31 20 85-1
ceratizit.com

